

Guideline for Ultrasonic Thickness Measurements of ships classed with Det Norske Veritas



Table of content

1. Objective and applicability	3
2. Terms and abbreviations	4
3. A few basics	6
4. Procedure for class surveys and thickness measurements onboard ships	7
<i>4.1 DNV surveyor to be onboard</i>	7
<i>4.2 Kick-off meeting</i>	7
<i>4.3 Requirements to cleaning</i>	7
<i>4.4 Means of access</i>	9
<i>4.5 Execution of the Thickness Measurements on board.</i>	11
<i>4.6 Reporting</i>	12
5. Requirements to the UTM company	13
6. Extent of thickness measurements	15
<i>6.1 All ships - Systematic requirements</i>	16
<i>6.2 General dry cargo ships - Systematic requirements</i>	21
<i>6.3 General dry cargo ships - Measurements i.w.o. close-up inspections</i>	25
<i>6.4 Bulk carriers ESP - Systematic requirements</i>	31
<i>6.5 Bulk carriers ESP - Measurements i.w.o. close-up inspections</i>	35
<i>6.6 All ESP Tankers- Systematic requirements</i>	39
<i>6.7 Single Hull Oil Tankers, Ore/Oil Ships ESP - Measurements i.w.o. close-up inspections</i>	43
<i>6.8 Double Hull Oil Tankers, Ore/Oil Ships ESP - Measurements i.w.o. close-up inspections</i>	46
<i>6.9 Chemical tankers ESP - Measurements i.w.o. close-up inspections</i>	50
7. Thickness measurement pattern	53
<i>7.1 Number of measurement points per plate and averaging</i>	53
<i>7.2 Transverse sections</i>	54
<i>7.3 Bulkheads and web frames</i>	55
<i>7.4 Measurements i.w.o. close-up inspections</i>	55
<i>7.5 Figures with location of measurement points</i>	56
<i>7.6 Mapping of areas with substantial corrosion</i>	64
Appendix A Kick-off meeting – Agenda and Minutes of Meeting	65
Appendix B - Approval Programme No. 402 April 2004 : Approval of Firms Engaged in Ultrasonic Thickness Measurements of Ship's Structure.	67
Appendix C - Approval Programme No. 402 May 2001 : Approval Programme for Service Suppliers Engaged in Thickness Measurements on Ships, High Speed and Light Craft and Mobile Offshore Units.	72
Appendix D Mapping of areas with substantial corrosion	77
Appendix E Example of UTM report front page	84
Appendix F - Calculation of average thickness reduction in deck and bottom. Verification of longitudinal strength	85
Appendix G Guidelines for measurements of side frames in bulk carriers	87

1. Objective and applicability

This guideline is prepared by Det Norske Veritas for ship owners, operators, yards and service suppliers approved for thickness measurements of ship's structure, in order to facilitate co-operation through a common understanding of the procedures for UTM (ultrasonic thickness measurements) at Class Surveys. CAP is not covered by this guide. A separate UTM specification for CAP may be downloaded at : <http://www.dnv.com/maritime/maritimeconsulting/technicalsolutions/cap/index.asp> .

This guide applies to all types of steel ships classed with DNV.



Fig.1.1

Steel plates in the deck being replaced after UTM. Evenly corroded steel plates might look perfectly acceptable even at close-up distance. Thus, thickness measurements are an essential part of class surveys.

If you have any comments or questions to this guide, please send an e-mail to : MTPNO864@dnv.com.

If any person suffers loss or damage which is proved to have been caused by any negligent act or omission of Det Norske Veritas, then Det Norske Veritas shall pay compensation to such person for his proved direct loss or damage. However, the compensation shall not exceed an amount equal to ten times the fee charged for the service in question, provided that the maximum compensation shall never exceed USD 2 million. In this provision "Det Norske Veritas" shall mean the Foundation Det Norske Veritas as well as all its subsidiaries, directors, officers, employees, agents and any other acting on behalf of Det Norske Veritas.

2. Terms and abbreviations

See also DNV Rules Pt.7 Ch.2 Sec.1 A100 for additional definitions.

Approval Prog. No.402	Requirements forming the basis for accepting a service supplier to do ultrasonic thickness measurements onboard steel ships for class. Included in Appendix B and C of this document.
Conditions	Conditions are issued to ship owners by class, in order to impose improvements, additional surveys or other actions to ensure compliance with rule requirements.
CA	A condition on behalf of a flag state that will be issued if the condition is related to statutory surveys where DNV has been authorised. (Pt.1 Ch.1 Sec.3 B803 of the DNV Rules)
CAP	Condition Assessment Program. Voluntary hull condition survey, where a ship's hull, machinery or piping system is given one of the following ratings; 1 - Very good condition, 2 - Good condition, 3 - Satisfactory condition or 4 - Poor condition (below acceptable class standard).
CAS	Condition Assessment Scheme. Increased survey/reporting scope, where the classification society will send a hull condition report to the flag state for their acceptance to let the ship continue trading. Applies to single skin tankers >15 years on their first intermediate or renewal survey after 5th. of April 2005.
Category I	Service suppliers approved to do thickness measurements for class onboard all DNV steel ships.
Category II	Service suppliers approved to do thickness measurements for DNV onboard fishing vessels of all sizes and non-ESP ships below 500 GT.
Category II Extended	Service suppliers approved to do thickness measurements for DNV onboard fishing vessels of all sizes and non-ESP ships of less than 100m. length, except general cargo ships (with MO Ref. 129).
CC	A Condition of Class will be issued if a condition is related to requirements set by the rules. A CC is subject to specified rectification (e.g. repairs) or operation (e.g. survey) and shall be carried out within a given time limit, in order that the ship retain class. (Pt.1 Ch.1 Sec.3 B802 of the DNV Rules).
C.N.72.1	Classification Notes No.72.1 "Allowable Thickness Diminution for Hull Structure"
ESP	Enhanced Survey Program. Requirements for planning, execution and reporting for hull surveys of oil/chemical tankers, obo and bulk carriers.
Excessive corrosion	An extent of corrosion that exceeds the allowable limit, so that steel must be replaced. Ref. Fig.2.1.
Extensive corrosion	An extent of corrosion consisting of hard and/or loose scale, including pitting, over 70% or more of the area under consideration, accompanied by evidence of thickness diminution.

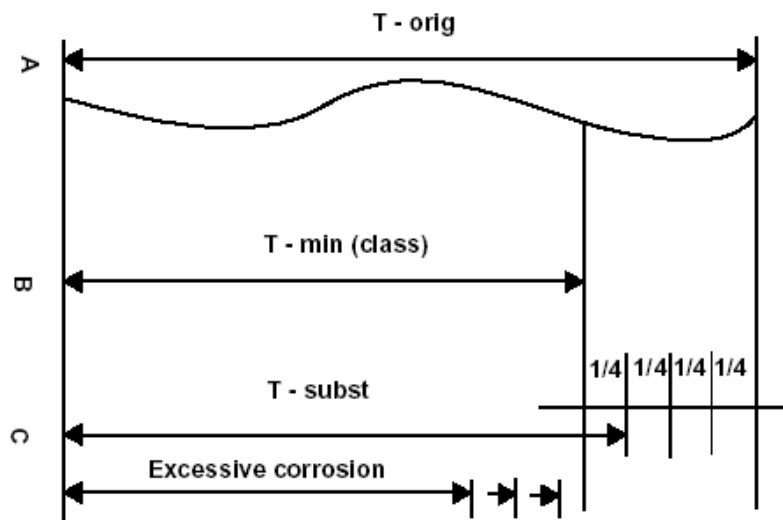

Fig.2.1

IACS	International Association of Classification Societies. DNV is one of 12 member classification societies, which all have to abide by common IACS rules. The other member societies are American Bureau of Shipping, Bureau Veritas, China Classification Society, Germanischer Lloyd, Lloyd's Register of Shipping, Nippon Kaiji Kyokai, Korean Register, Polski Rejestr Statkow, Registro Italiano Navale, Rinave Portuguesa and Register of Shipping of the U.S.S.R.
Minimum thickness list	List of minimum acceptable thickness values for the structural parts of a ship. An individual list will be made by DNV for each and every ship which is to be measured.
MTP	Maritime Technology and Production (DNV centre at Høvik, Norway).
Substantial corrosion	Where less than 25% of the corrosion margin is left, yet thickness is higher than for excessive corrosion. See figure. Limits are stated in the minimum thickness list.
Tmin	Minimum allowable thickness. Calculated by class and entered into a minimum thickness list. If a steel plate or profile corrodes to a thickness less than this value, it will normally have to be replaced.
Tmin list	See minimum thickness list
Tsubst	See "Substantial corrosion"
UTM	Ultrasonic Thickness Measurements. Used to determine the thickness of steel plates and profiles.

3. A few basics

1. All thickness measurements done onboard DNV ships, where the results are used by the class surveyor to evaluate the strength, shall be done by a DNV approved service supplier with a valid DNV certificate.
2. Thickness measurements done for class, as described in point 1, shall be done with a DNV surveyor onboard.
3. DNV and IACS have specific requirements to access and cleaning to be prepared for close-up surveys combined with UTM (see 4.3 and 4.4). Access and cleaning is owner's responsibility.
4. Prior to every major thickness measurement project onboard, such as for intermediate or renewal survey, a meeting between DNV, the service supplier and the owner shall be held. If a thickness measurement project is divided up in separate smaller UTM jobs, a new meeting shall be held prior to each job.
5. After 1st. of January 2005, only multiple echo instruments may be used for UTM onboard all ships. This applies for both Category I and Category II UTM companies.
6. After 1st. of January 2005, the Category I service suppliers shall provide two operators for all major thickness measurement jobs (Intermediate Survey and Renewal Survey) done onboard ships. For a definition of Category I and Category II companies, see 2, "Terms and Abbreviations".
7. After 1st. of January 2005, all operators in Category I companies doing measurements onboard DNV ships shall be qualified and registered at the certifying DNV station. They shall be able to communicate in English and to understand ship's main hull drawings. If subcontractors are used, they shall be subcontracted from another DNV certified company. Otherwise the operators will be rejected. For a definition of Category I and Category II companies, see 2, "Terms and Abbreviations".
8. The surveyor onboard shall be kept continuously informed about discovered areas with under minimum thickness, and other structural defects such as cracks, grooving and buckling.
9. Based on the results coming up, the surveyor may always order additional measurements to be taken.
10. After 1st. of January 2005, a DNV electronic reporting form shall be used for all the thickness measurement reports made by Category I UTM companies. The form can be downloaded from DNV's website at : <http://www.dnv.com/maritime/maritimeconsulting/technicalolutions/cap/index.asp> under "Downloads". The same form may be used for Class, CAP and CAS. For a definition of Category I companies, see 2, "Terms and Abbreviations".
11. After 1st. of January 2005, the thickness measurement report made by Category I companies shall be filled in throughout the project and results made available to the surveyor onboard. A preliminary report shall be given to the attending DNV surveyor before leaving the ship. For a definition of Category I and Category II companies, see 2, "Terms and Abbreviations".
12. After 1st. of January 2005, the final thickness measurement report for category I ships shall be issued within 2 weeks after the thickness measurement job is completed. For a definition of Category I and Category II companies, see 2, "Terms and Abbreviations".

4. Procedure for class surveys and thickness measurements onboard ships

Ref. to the DNV Rules Pt.7 Ch.1 Sec. 3 B.

4.1 DNV surveyor to be onboard

A DNV surveyor shall be onboard, to the extent he or she finds necessary to control the process, when thickness measurements are done for class. Measurements which have not been carried out in co-operation with DNV can not be accepted. The UTM company shall inform the owner accordingly. Ref. DNV Rules Pt.7 Ch.1 Sec.3 B200. This applies to all steel ships where the measurements will make the basis for the surveyor's decisions during class surveys. Thickness measurements which per our rules are required in connection with close-up examination (such as web frames and transverse bulkheads), shall always be taken with the surveyor in attendance.

When onboard the operator/supervisor shall have his certificate and identification papers readily available for verification.

The operator shall notify the DNV surveyor of any structural deficiencies, such as cracks, indents, buckling or abnormal measurements detected.

4.2 Kick-off meeting

The DNV rules require a meeting for planning of the thickness measurements, including Owners representative, UTM company and DNV. See Appendix A for an agenda/Minutes of Meeting form to be used for these meetings. The meeting shall clarify initial scope of close-up examination and thickness measurements.

At the meeting, unless requested earlier, the surveyor will hand over the minimum thickness list. For ESP ships it may be found in the Survey Programme. The minimum thickness list is individual for each and every ship, and shall always be made by DNV. Upon receiving the minimum thickness list, the UTM operators shall enter the minimum thickness values into the UTM report template, prior to commencing thickness measurements, in order to facilitate the evaluation of the results on a day by day basis onboard.

4.3 Requirements to cleaning

Cleaning is the owner's responsibility. The Owners should ensure that efficient means for de-scaling is available at the survey, i.e. hydro or sandblasting equipment. When satisfactory de-scaling may not be arranged, the surveyor will only be able to provide a preliminary specification of necessary upgrading, without crediting the tank. A new survey will be carried out after de-scaling, additional thickness measurements may be required and the scope of repairs extended.



Fig. 4.3.1

Optimal conditions for inspection : Grit blasted, dry and clean, with all sediments, loose coating and rust flakes removed. Thickness reductions and cracks are easily spotted with the naked eye.



Fig. 4.3.2

What is sometimes presented for inspection : No cleaning whatsoever. Two men have been sent along to “hack away loose scale where needed”. This is not acceptable according to our rules, and the inspection should be rejected by the surveyor.

Please note that the DNV Rules, as well as IACS, do have requirements to the cleanliness during surveys :

Ref. DNV Rules Pt.7 Ch.1 Sec.3 B 101 :

In preparation for survey and to allow for a thorough examination, all spaces shall be cleaned including removal from surfaces of all loose accumulated corrosion scale. In tanks where soft coatings have been applied, representative areas, and those areas where it is obvious that further close-up examination is required, shall be cleaned free of soft coating.

Guidance note:

Spaces should be sufficiently clean and free from water, scale, dirt, oil residues etc. to reveal corrosion, deformation, fractures, damage, or other structural deterioration. However, those areas of structure whose renewal has already been decided by the owner need only be cleaned and descaled to the extent necessary to determine the limits of the renewed areas. For more detailed information with regard to a tank where soft coatings have been applied, see IACS Recommendation No. 44.

---e-n-d---of---G-u-i-d-a-n-c-e---n-o-t-e---

Ref. IACS Unified Requirements Z7 Ch.5.1.3 :

In preparation for survey and thickness measurements, and to allow for a thorough examination, all spaces are to be cleaned including removal from surfaces of all loose accumulated corrosion scale. Spaces are to be sufficiently clean and free from water, scale, dirt, oil residues etc. to reveal corrosion, deformation, fractures, damages, or other structural deterioration. However, those areas of structure whose renewal has already been decided by the owner need only be cleaned and descaled to the extent necessary to determine the limits of the renewed areas.

4.4 Means of access



Fig. 4.4.1 Temporary staging during renewal survey of an oil tanker

Access is the owner's responsibility.

Ref. DNV Rules Pt.7 Ch.1 Sec.3 B102 :

Quote :

For close-up examination, one or more of the following means for access shall be provided:

- permanent staging and passages through structures
- temporary staging and passages through structures
- lifts and moveable platforms
- boats or rafts
- other equivalent means.

End quote.

Please note that in July 2004, IACS introduced restrictions to the use of rafting in the upper area of tanks.



Fig. 4.4.2 Rafting

Ref. DNV Rules Pt.7 Ch.1 Sec.3 B103 :

Quote :

Rafts or boats alone may be allowed for survey of the under deck areas for tanks or spaces, if the depth of the webs is 1.5 m or less.

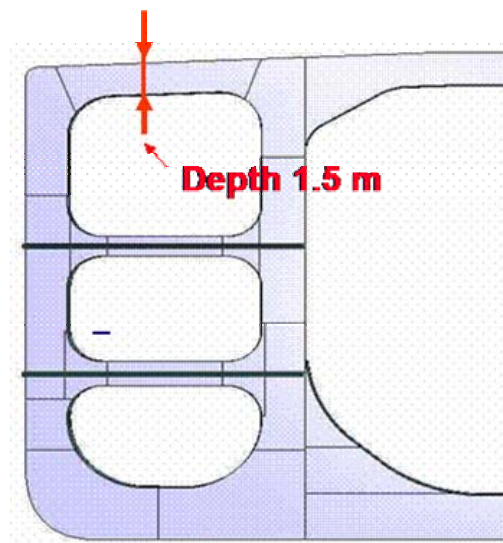

Fig.4.4.3 Depth of web frame

If the depth of the webs is more than 1.5 m, rafts or boats alone may be allowed only:

- when the coating of the under deck structure is in GOOD condition and there is no evidence of wastage; or
- if rafts or boats are to be used with a water level above the face plate of the deck girders, an escape route through the air space is to be provided. This may be arranged with a permanent means of access in each bay to allow safe entry and exit with access direct from deck via a vertical ladder and a small platform fitted approximately 2 m below deck.

If neither of the above conditions are met, then staging or "other equivalent means" of access shall be provided for the survey of the under deck areas.

Unquote

The restriction has been made to protect the persons doing the rafting, in the case of an emergency.



Fig. 4.4.4 Schematic illustration of how close-up may be achieved without rafting underneath deck. Temporary staging is placed between the flanges of the web frames. Tank is partly filled for safety reasons.

One example of "other equivalent means" may be to use temporary, portable staging fitted between the flanges of two web frames, with partial filling of the tank (with a water level well below the web frames) for safety.

Alternatives with climbers doing thickness measurements while carrying a camera, in order to let the surveyor do the close-up survey by watching a TV screen onboard, will only be accepted on a case by case basis, and must be clarified with DNV well in advance of the survey.

4.5 Execution of the Thickness Measurements on board.

Prior to commencing the thickness measurements, the surveyor will :

- Check type of equipment and verify that the equipment is calibrated according to recognized national / international standards and properly labelled.
- Witness calibration appropriate for size and type of material.
- Be satisfied with operator's competence and documentation.

The operators shall keep the equipment and required certificates ready for inspection at commencement of measurements. For requirements to equipment and operators, see Ch.5.

The surveyor will direct the gauging operation by selecting locations such that readings taken represent, on average, the condition of the structure for that area.

Thickness measurements mainly to evaluate the extent of corrosion which may affect the hull girder strength (transverse sections), should be carried out in a systematic manner of all longitudinal, structural members. See Ch. 7 for a figure showing correct pattern. The surveyor should be in attendance during this process. The location of the sections longitudinally shall be decided by the surveyor, and will normally be decided after deck and bottom plating has been measured, where required, in order to determine which areas have corroded the most. The sections should be placed where the upper and lower plating has corroded the most. One transverse section will normally be placed amidship.

Thickness measurements of structures in areas where close-up surveys are required should be carried out simultaneously with the close-up surveys in order to facilitate a meaningful survey.

The surveyor may specially consider the extent of ("waive") thickness measurements of certain structures, within spaces where the protective coating is found to be in GOOD condition, but there are restrictions to how much of the measurements may be waived. In any case, ask the surveyor what may be waived in each case.

The thickness measurement operators shall keep the surveyor continuously informed (e.g. at the end of each day of measurements) about measurement results and structural deficiencies found, such as excessive or substantial corrosion, cracks, indents or buckling. If doubler plates used as repairs are discovered inside oil tanks or on oil/water boundary plating or stiffeners, this shall also be informed to the surveyor.

Where thickness measurements indicate substantial corrosion or excessive diminution, the UTM company shall contact the DNV surveyor onboard in order to get directions for additional thickness measurements, in order to map the areas of substantial corrosion, and to identify structural members for repairs / renewals. The DNV Rules Pt.7 Ch.2 and Appendix D of this document contain tables detailing how such areas shall be mapped.

Upon completion of the thickness measurements, the surveyor must have confirmed that no further gauging is needed, before the job of taking measurements can be regarded as completed. The rule requirements detailed in ch.6 are always to be considered the minimum scope for thickness measurements.

Upon completion of the thickness measurements onboard, the surveyor shall verify and sign the preliminary thickness measurement report. A copy of the preliminary report shall be given to the attending surveyor before leaving the ship.

See also 4.6 for reporting procedures.

4.6 Reporting

Procedures for reporting are given in DNV's "Standards for Certification" No. 2.9, Programme No.402: "Approval of Firms Engaged in Ultrasonic Thickness Measurements of Ship's Structure". At the moment there are two different versions of that programme, the May 2001 and the April 2004 version. Which version which will apply for a particular UTM job, is depending on date of survey and ship type, and detailed in the first part of chapter 5.

The May 2001 revision of the Approval Programme No. 402 (Appendix C) specifies that the UTM report shall be "in a form acceptable to DNV", and "shall include a copy of the certificate of approval" for the UTM company. The front page should also inform about date and place of measurements, number of pages in the report and which company did the measurements. The front page should be stamped and signed by the DNV surveyor. In addition, there is an IACS requirement stating that a minimum thickness list shall be attached to the UTM report if the min. thickness values used are not included in the report itself.

The April 2004 revision of the Approval Programme No. 402 (Appendix B) require the UTM company to write its reports using a standardised DNV format, available on the DNV web site at : <http://www.dnv.com/maritime/maritimeconsulting/technicalolutions/cap/index.asp> under "Downloads". The format is the same as the one being used by CAP and CAS.

THICKNESS MEASUREMENT REPORT

Ship's Name: Exampleship		Id.No: 12345		Report No: UTM-Co No.9876		Legend		Substantial corr		Below class min		Comments, Defects found	
Tank / Space	Tank/Space Reverse side	Structural Element	Element / Frame No.	Draw ref.	Orig thk. mm	Class min thk. mm	Gauged		Diminution		Renewed		
							Port mm	Stbd mm	Port %	Starboard %	Port mm		Stbd mm
TRANSVERSE SECTION FR. 74-75													
DECK													
WT4		Longitudinal stiffener, web	L1	S4-1	12,50	8,00	9,00	11,90	3,56	28,0%	0,60	4,8%	
WT4		Longitudinal stiffener, flange	L1	S4-2	12,50	8,00	10,00	12,00	2,50	20,0%	0,50	4,0%	
WT4		Longitudinal stiffener, web	L2	S4-3	12,50	8,00	10,20	12,30	2,30	18,4%	0,20	1,6%	
WT4		Longitudinal stiffener, flange	L2	S4-4	12,50	8,00	7,20	12,40	5,30	42,4%	0,10	0,8%	
WT4		Longitudinal stiffener, web	L3	S4-5	12,00	8,00	8,50	11,50	3,56	29,2%	0,50	4,2%	
WT4		Longitudinal stiffener, flange	L3	S4-6	12,00	8,00	11,40	11,80	0,60	5,0%	0,20	1,7%	
WT4		Longitudinal stiffener, web	L4	S4-7	12,00	8,00	11,70	10,00	0,30	2,5%	2,00	16,7%	
WT4		Longitudinal stiffener, flange	L4	S4-8	12,00	8,00	11,80	11,50	0,20	1,7%	0,50	4,2%	
WT4	Maindeck	Deck plating, spacing L1-L2	"L1-L2"	S4-9	12,00	8,00	10,00	11,50	2,00	16,7%	0,50	4,2%	

Prior to commencement, the UTM company shall enter the original thickness and minimum thickness values for the structural parts to be measured into the report format. All these values will be stated in the minimum thickness list, which shall be prepared by DNV. The report shall also inform which parts of the structure has been replaced, and it should include a clear indication of which transverse sections have been measured, when applicable. The report shall be prepared onboard, with measurements being filled in on a daily basis, and made available for the surveyor upon request.

Upon completion of the measurements onboard, a digital copy of the preliminary report, with all measurements entered, shall be given to the attending surveyor before the UTM company leave the ship. Sketches showing the location of measurement points shall also be given to the surveyor, but need not be digital.

Final report shall be sent to DNV no later than 2 weeks after the measurements are finished. The final report shall consist of one digital copy and one paper copy or digital copy in non-editable form (e.g. a .pdf file). Content of the paper copy or the non-editable digital copy should be as for the preliminary report, with integrated sketches showing measurement points, but in addition it shall contain a front page with a stamp and signature from the operator and the attending surveyor. The front page shall inform about date and place of measurements, number of pages in the report and which company did the measurements. An example is given in Appendix E.

See Appendix F for a guide on how to calculate average corrosion in deck and bottom, where this is demanded by the surveyor.

5. Requirements to the UTM company

UTM shall be carried out by an approved UTM company and with a DNV Surveyor present. The company shall have a valid DNV certificate, authorising the company to do measurements onboard the ship type in question (ref. below). The category of the company will be stated in the company's certificate.

The requirements used as basis for certification of a UTM company, is given in "Standards for Certification" No. 2.9, Approval Programme No.402, "Approval of Firms Engaged in Ultrasonic Thickness Measurements of Ship's Structure". A copy of the programme may be found in Appendix B of this document.

Important ! : Approval Programme no. 402 was revised in April 2004. The new revision separates all UTM companies into three categories :

Category I : Authorised to do measurements on all types and sized of ships classified by DNV.

Category II : Authorised to do measurements on fishing vessels of all sizes, and on non-ESP ships below 500GT.

Category II, Extended : Authorised to do measurements on fishing vessels of all sizes, and on all non-ESP ships with length less than 100 meters, except general cargo ships (with MO Ref. 129).

After January 2005 companies which haven't implemented additional requirements listed in the new programme will automatically become "Category II" UTM companies.

A UTM company may be converted into an "Extended Category II" company by contacting certifying DNV station. If the station can verify that the company satisfies the IACS Z17 requirements, in addition to the Category II company requirements described in cert. prog. 402, certifying station may issue an "Extended Category II" certificate.

Companies which choose to become Category I companies, must first implement the additional requirements set in the new 402 programme. After compliance has been verified through an audit, these companies will be labelled "Category I" UTM companies, and may do thickness measurements for DNV onboard all types and sizes of ships. For a complete list of the new requirements, see Appendix B. However, some of the most important, new requirements introduced in the April 2004 edition are given here:

Some of the most important, new requirements introduced in the April 2004 edition are given below :

1) Instruments using pulsed echo technique, either with oscilloscope or digital instruments using multiple echo, single crystal technique are required. Single echo instruments are not accepted. (Previously single echo instruments were accepted on un-coated surfaces). A confirmation from the manufacturer that the instruments

satisfy this requirement shall be enclosed with the instrument record. This is the only new requirement which will apply to both Category I and Category II companies after January 2005.

2) Each major class job (Intermediate Survey and Renewal Survey) is to be carried out by at least two qualified operators working together. Operators shall carry ID cards with a photo. An updated list of approved operators shall be kept at the approving DNV office, so that qualifications can be verified by attending surveyor. Readings taken by non-listed operators will be rejected. Subcontractors shall not be used, unless they come from another DNV certified company. Operators shall be able to speak English, understand ship's drawings and be able to choose a representative position for each measurement.

3) For work procedures and reporting, see 4.5 and 4.6.

Some key requirements taken from the May 2001 version of Approval Programme No.402 :









- On coated surfaces, instruments using pulsed echo technique (either with oscilloscope or digital instruments using multiple echo, single crystal technique) are required. Single echo instruments may be used on uncoated surfaces. A record of the equipment used for thickness measurement shall be kept. The record shall contain information on maintenance and calibration. (After January 2005 multiple echo instruments must be used by both Category I and Category II companies).
- The supplier shall keep records of the approved operators. The record shall contain information on age, formal education, training and experience.
- The operator carrying out the measurements shall be certified to EN 473 Level I, ISO 9712 Level I or a corresponding standard and have passed the internal training scheme of the supplier. The operator shall also have at least one year's experience as an assistant operator (minimum 10 different assignments).
- For work procedures and reporting, see 4.3 and 4.4.

6. Extent of thickness measurements

The rule requirements to the extent of thickness measurements for ships are specified in the DNV rules Pt.7 Ch.2 Sec.2 Table D3, with enhanced requirements for general cargo ships, bulk carriers and tankers in Pt.7 Ch.2 Sec.2 Tables E2 and Pt.7 Ch.2 Sec.3 F2, G3, G4 and K2. Each table will correspond to one specific ship type. All tables are given with illustrations in 6.1.

The requirements vary with ship type, age and survey type, and may generally be divided in three groups:

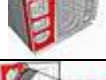
1. Systematic requirements including measurements of shell plating and transverse sections, to help evaluate the overall strength of the ship. The requirements should not be waived due to GOOD coating, but the extent of measurement points may be reduced to some extent. What may be waived shall always be decided by the surveyor, who may also decide to increase the scope based on findings onboard. The requirements are given in tables 6.1, 6.2, 6.4 and 6.6 below, pending on ship type. Measurement pattern (number of measurement points per structural part) is described in ch.7.
2. Measurements for assessment of corrosion level i.w.o. close-up inspections. A guideline for initial extent of measurements is given in tables 6.3, 6.5 and 6.7 to 6.9 below, pending on ship type. The requirements may be partly waived in case original coating is in GOOD condition, to be decided by the surveyor. The surveyor may also decide to increase the scope based on findings onboard. Measurement pattern (number of measurement points per structural part) is described in ch.7.
3. Mapping of areas found with Substantial Corrosion
 Areas found with Substantial Corrosion, as defined in ch.2, at previous surveys or through the measurements described in 1 and 2, should be subject to intensive measurements. The required measurement pattern is thoroughly defined in the rules Pt.7 Ch.2 and given in tables in Appendix D of this document.

Index			
Ship type	Type of thickness measurements	Fig.	Page
All ships	Systematic requirements		16
General Dry Cargo Ships	Systematic requirements		21
General Dry Cargo Ships	Thickness measurements i.w.o. close-up insp.		25
Bulk carrier ESP	Systematic requirements		31
Bulk carrier ESP	Thickness measurements i.w.o. close-up insp.		35
All ESP Tankers	Systematic requirements		39
Oil tankers ESP, single hull	Thickness measurements i.w.o. close-up insp.		43
Oil tankers ESP, double hull	Thickness measurements i.w.o. close-up insp.		46
Chemical tankers ESP	Thickness measurements i.w.o. close-up insp.		50

6.1 All ships - Systematic requirements
 (DNV Rules Pt.7 Ch.2 Table D3)

Renewal survey No.1 (Age ~ 5 years) : Suspect areas.

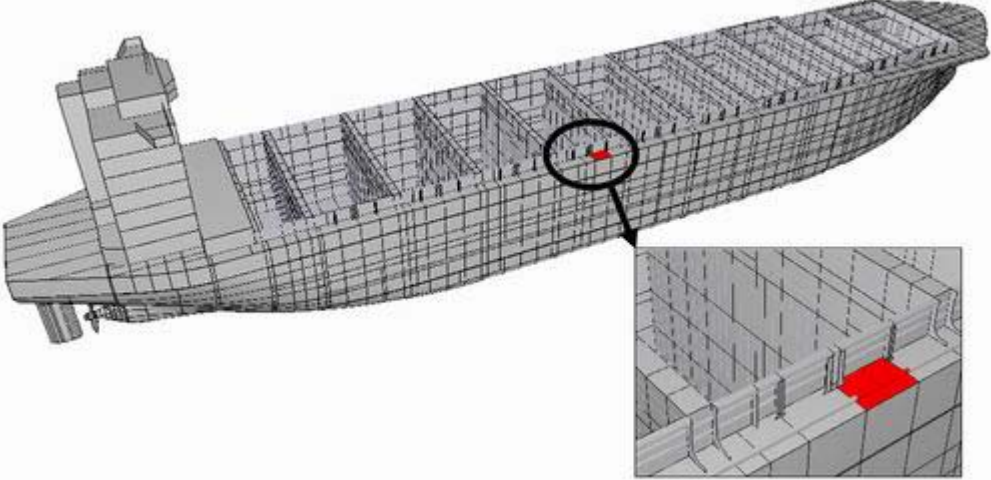
<i>All ships, systematic requirements - Renewal survey No.2 (Age ~ 10 years)</i>	
<i>1. Suspect areas.</i>	
	
<p><i>2. Within amidships 0.5L : One transverse section of deck plating abreast a cargo space.</i></p> <p>1) For details on measurement points, see ch.7. 2) Thickness measurement locations should be selected to provide the best representative sampling of areas likely to be most exposed to corrosion, considering cargo and ballast history and arrangement and condition of protective coatings.</p>	

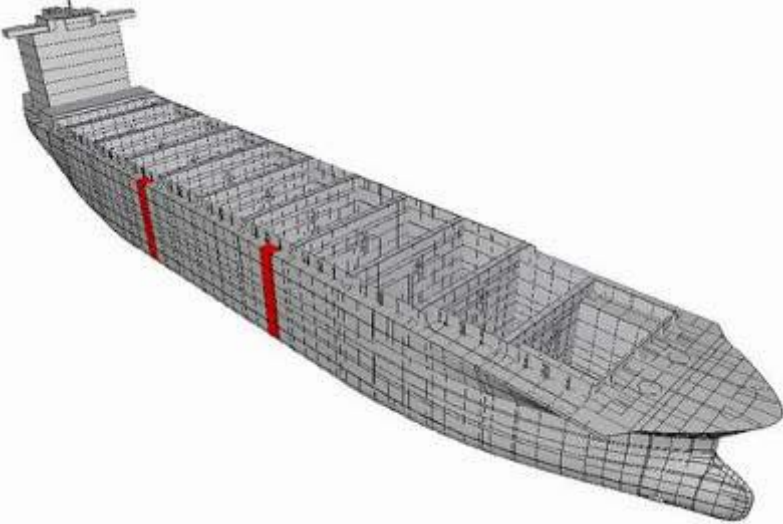
<i>All ships, , systematic requirements - Renewal survey No.3 (Age ~15 years)</i>	
<i>1. Suspect areas.</i>	
	
<p><i>2. Within amidships 0.5L: Two transverse sections abreast two different cargo spaces.</i></p>	

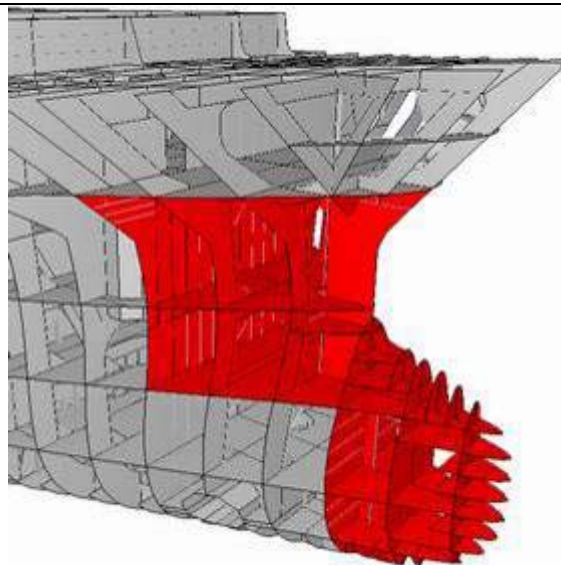

3. Internals in forepeak tank.

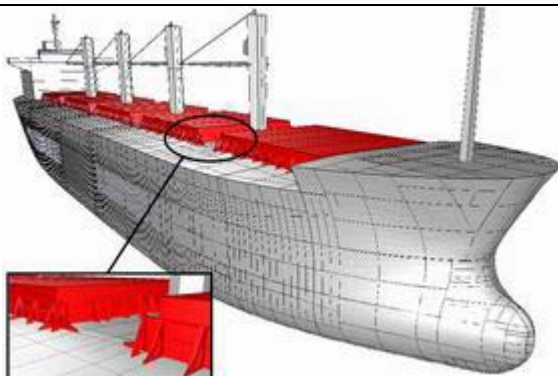

4. All cargo hold hatch covers and coamings (plating and stiffeners).



11. All air pipes and ventilators on the fore deck (forward 25% of ship's length), all air pipes to day tanks and selected air pipes and ventilator coamings aft of the forward 25% of the ship's length.

- 1) For details on measurement points, see ch.7.
- 2) The numbering of the requirements follows the numbering in the tables in rules Pt.7 Ch.2, and is not necessarily sequential (1,2,3, ..).
- 2) For ships less than 100 m in length, the number of transverse section required at renewal survey no. 3 may be reduced to one, and the number of transverse sections at subsequent renewal surveys may be reduced to two.
- 3) For ships more than 100 m in length, at renewal survey no. 3, thickness measurements of exposed deck plating within 0.5 L may be required.
- 4) Thickness measurement locations should be selected to provide the best representative sampling of areas likely to be most exposed to corrosion, considering cargo and ballast history and arrangement and condition of protective coatings.

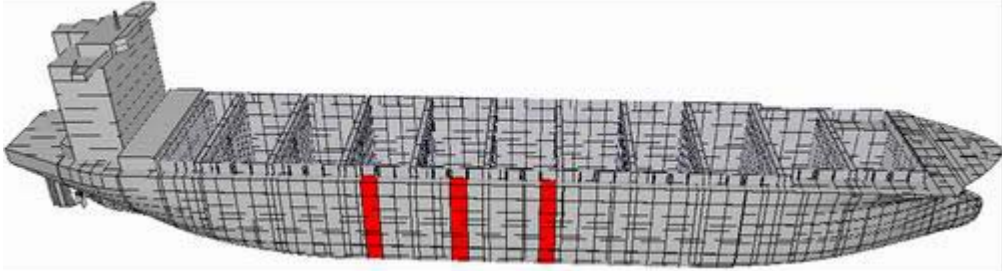
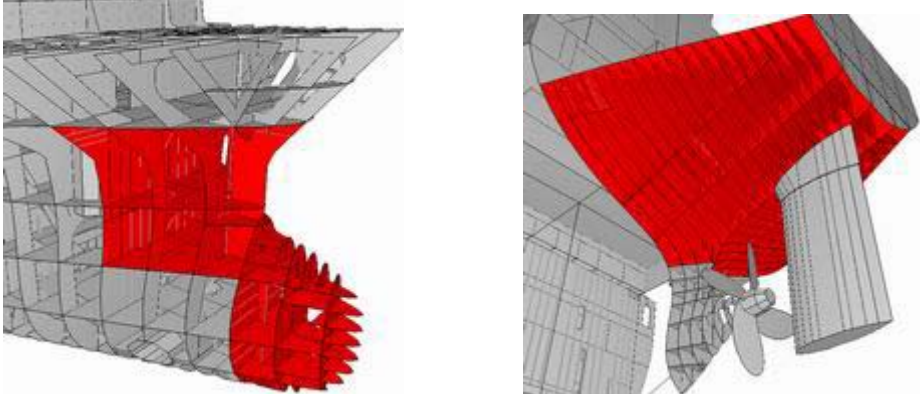
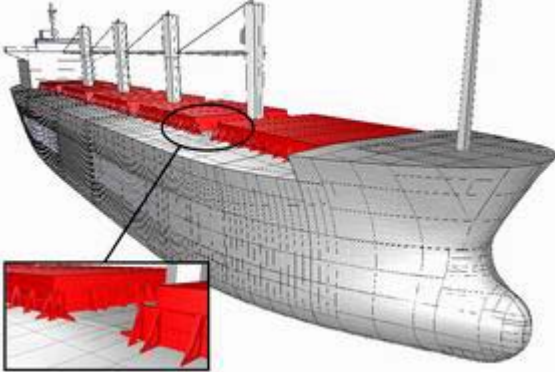
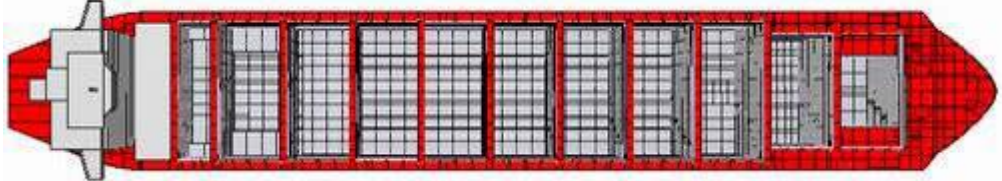
<p><i>All ships, systematic requirements - Renewal survey No.4 and subsequent (Age ~20 years and more)</i></p>	
<p>1. Suspect areas.</p>	
	
<p>2. Within amidships 0.5L : Three transverse sections in way of cargo spaces.</p>	
	
<p>3. Internals in forepeak tank and after peak tank.</p>	
	
<p>4. All cargo hold hatch covers and coamings (plating and stiffeners).</p>	
	
<p>5. All exposed main deck plating in full length.</p>	

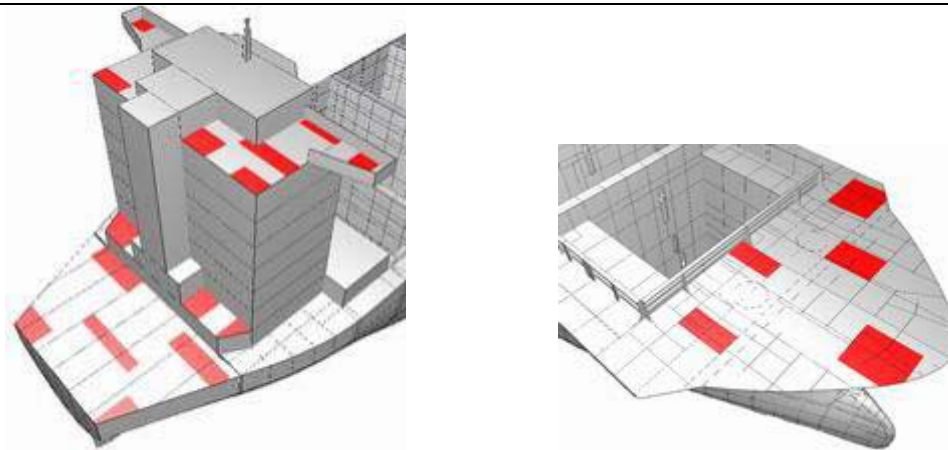

6. Representative exposed superstructure deck plating (poop, bridge and forecastle deck).

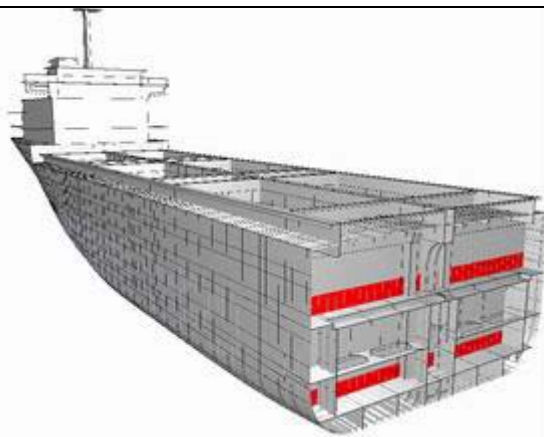

7. Lowest strake and strakes in way of tween decks of all transverse bulkheads in cargo spaces together with internals in way.

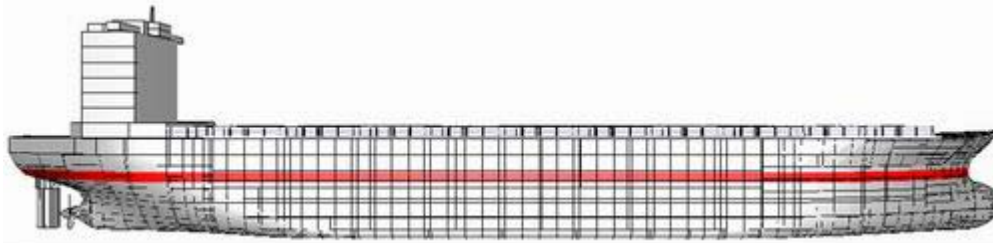

8. All wind- and water strakes, port and starboard, full length.

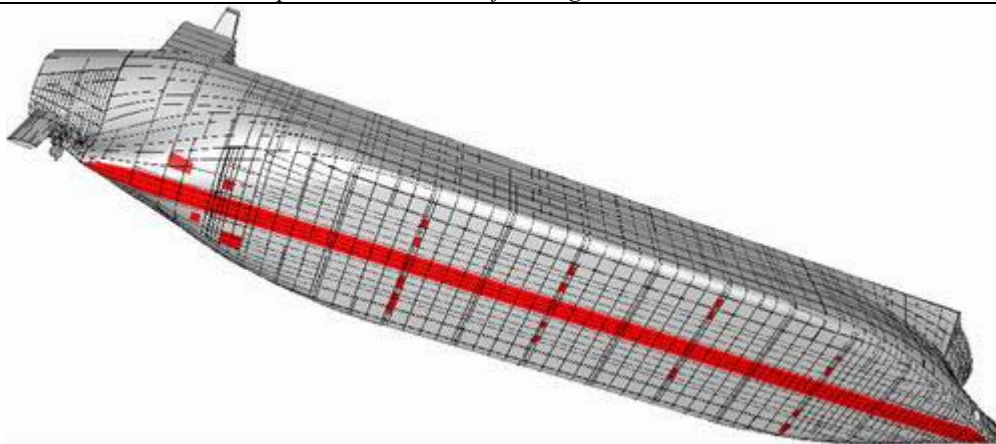

9. All keel plates full length. In addition, additional bottom plates in way of cofferdams, machinery space and aft end of tanks.



10. Plating of sea chests. Shell plating in way of overboard discharges as considered necessary by the attending surveyor.



11. All air pipes and ventilators on the fore deck (forward 25% of ship's length), all air pipes to day tanks and selected air pipes and ventilator coamings aft of the forward 25% of the ship's length.

- 1) For details on measurement points, see ch.7.
- 2) Thickness measurement locations should be selected to provide the best representative sampling of areas likely to be most exposed to corrosion, considering cargo and ballast history and arrangement and condition of protective coatings.

6.2 General dry cargo ships - Systematic requirements



(Table Pt.7Ch.2 Table E2)

<i>General dry cargo carriers, systematic requirements - Renewal survey No.1 (Age ~5 years)</i>	
1. Suspect areas.	

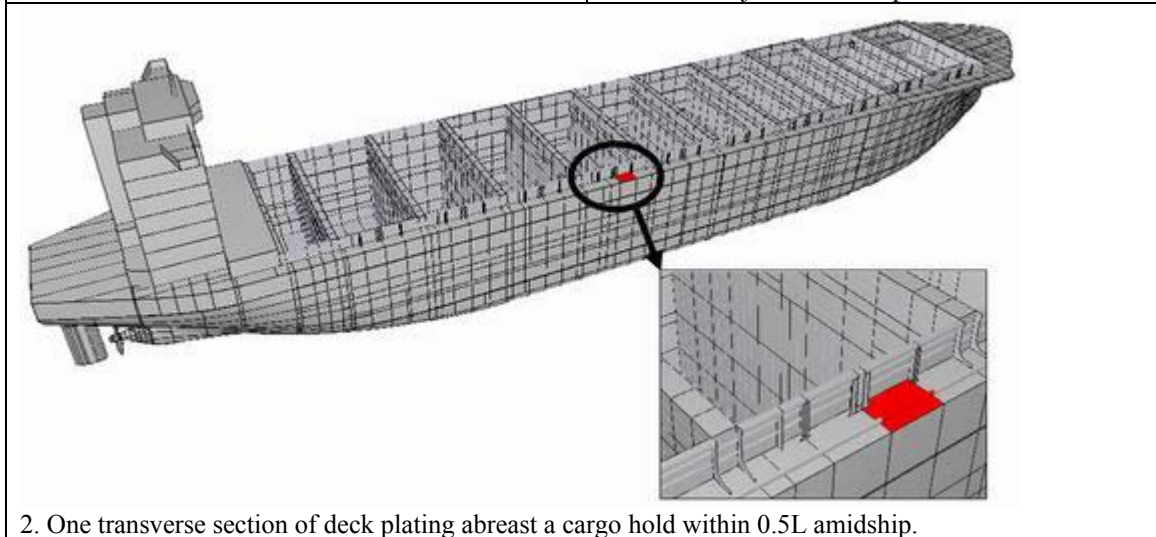
<i>General dry cargo carriers, systematic requirements - Renewal survey No.2 (Age ~ 10 years)</i>	
1. Suspect areas	3. Measurements, for general assessment and recording of corrosion pattern, of those structural members subject to close-up examination. See 6.3.

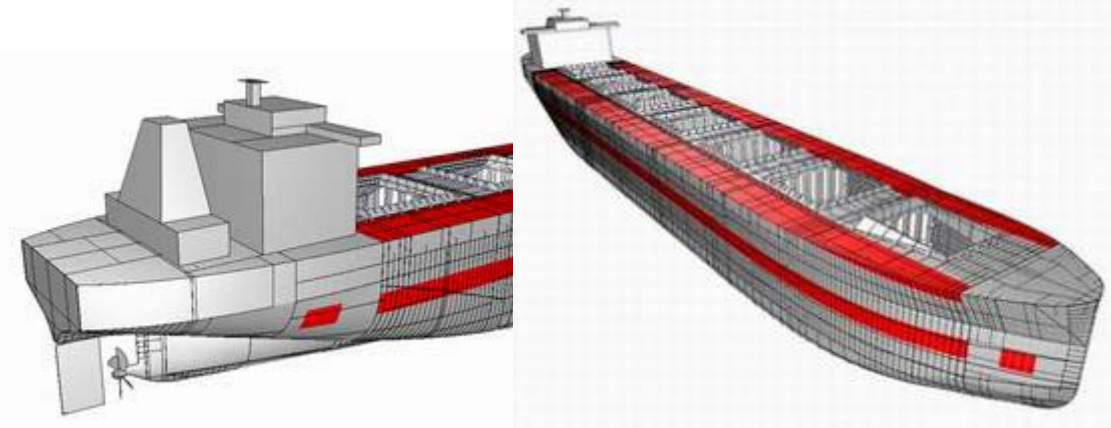
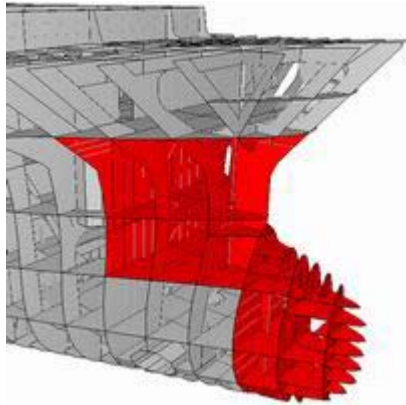

- 1) Requirements in 6.3 also apply.
- 2) For details on measurement points, see ch.7.

<i>General dry cargo carriers, systematic requirements - Renewal survey No.3 (Age ~ 15 years)</i>	
1. Suspect areas	3. Measurements, for general assessment and recording of corrosion pattern, of those structural members subject to close-up examination. See 6.3.
 <p>2. Two transverse sections within the cargo length area, where at least one section abreast a cargo hold within 0.5L amidship. See Note 2).</p>	
 <p>4. Each deck plate outside line of cargo hatch openings within the cargo length area. 5. All wind and water strakes (side shell plating between ballast and fully loaded water line) within the cargo length area. Selected wind and water strakes outside the cargo length area.</p>	
 <p>7. Internals in forepeak tank.</p>	 <p>10. All air pipes and ventilators on the fore deck (forward 25% of ship's length), all air pipes to day tanks and selected air pipes and ventilator coamings aft of the forward 25% of the ship's length.</p>

- 1) Requirements in 6.3 also apply.
- 2) For details on measurement points, see ch.7.
- 3) For ships less than 100m. in length, the number of transverse sections required at renewal survey no.3 may be reduced to one (1).
- 4) The numbering of the requirements follow the numbering in the rules Pt.7 Ch.2, and is not necessarily sequential (1,2,3..).

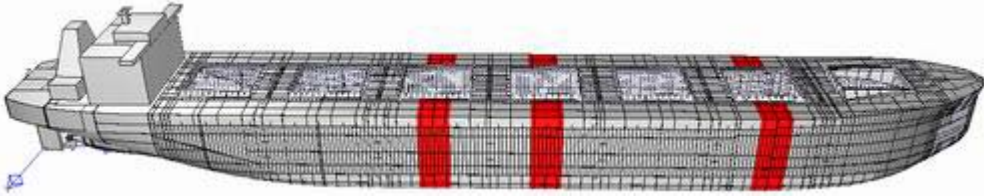
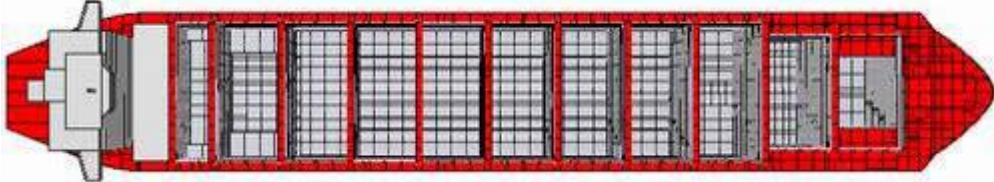
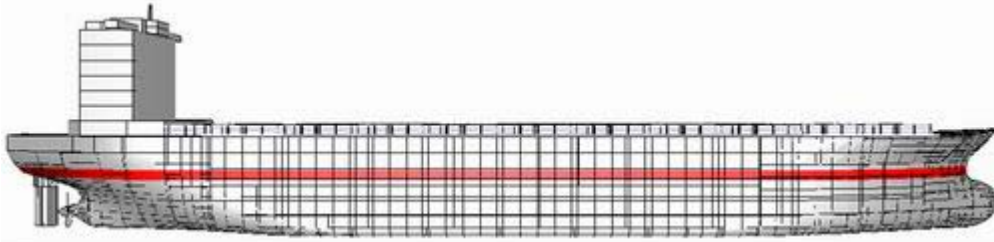
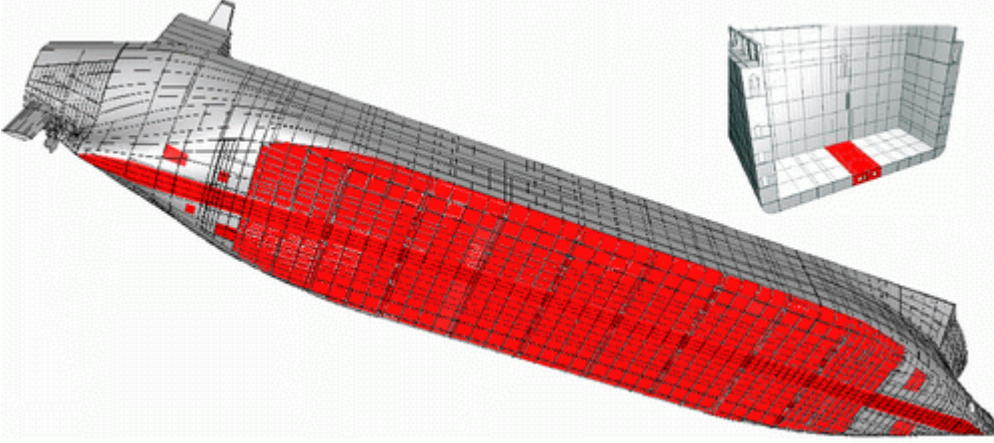
<i>General dry cargo carriers, systematic requirements - Renewal survey No.4 and subsequent surveys (Age ~ 20 years)</i>	
1. Suspect areas.	3. Measurements, for general assessment and recording of corrosion pattern, of those structural members subject to close-up examination. See 6.3.
	
2. Three transverse sections within the cargo length area, where at least two sections abreast two different cargo spaces within 0.5L amidship, as applicable. See Note 2.	
	
4. All exposed main deck plates full length.	
	
5. All wind and water strakes (side shell plating between ballast and fully loaded water line) full length of the ship.	
	
6. Each bottom plate, including lower turn of bilge, within the cargo length area. Duct keel or pipe tunnel plating and internals within the cargo length area. All keel plates full length, selected bottom plates in way of cofferdams, machinery space and tanks outside cargo length area.	

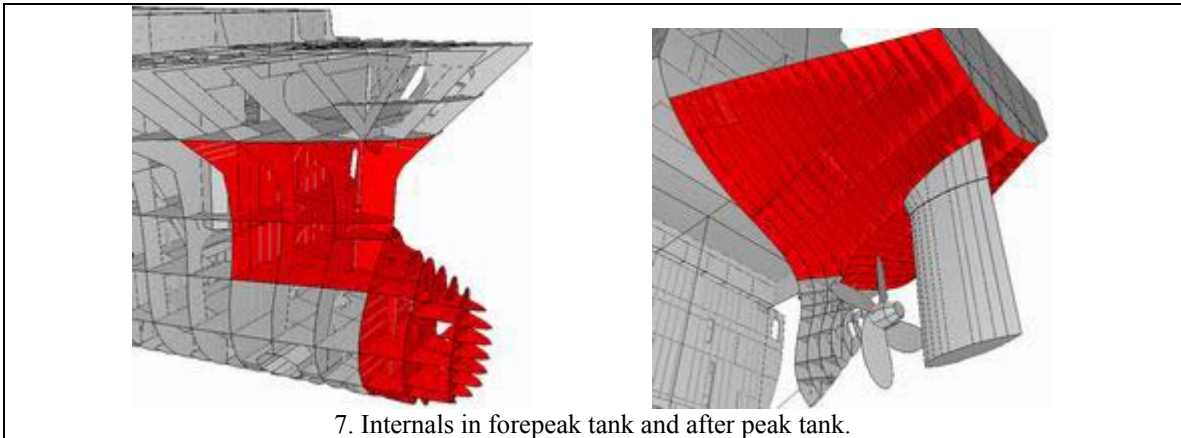

7. Internals in forepeak tank and after peak tank.

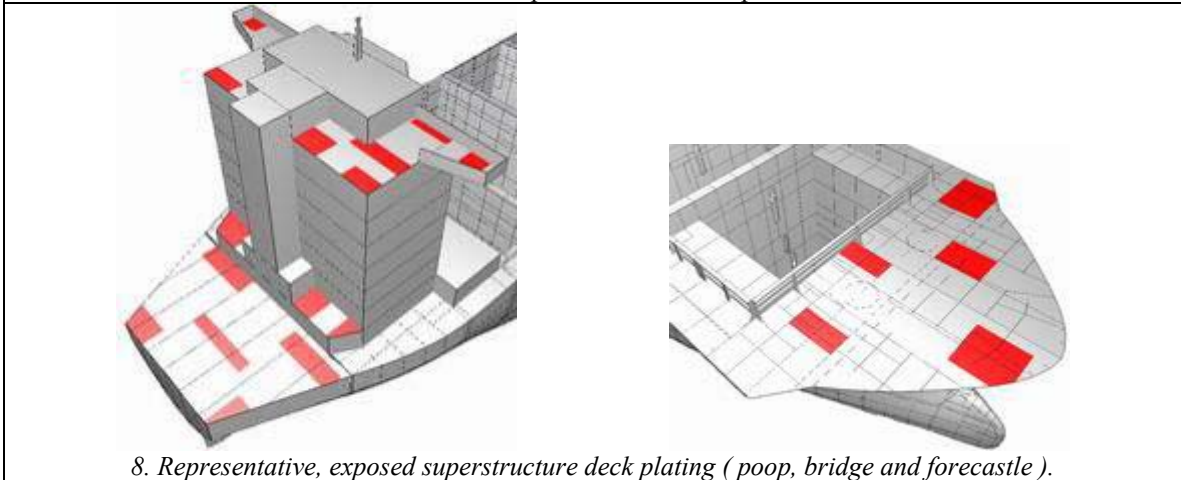

8. Representative, exposed superstructure deck plating (poop, bridge and forecastle).

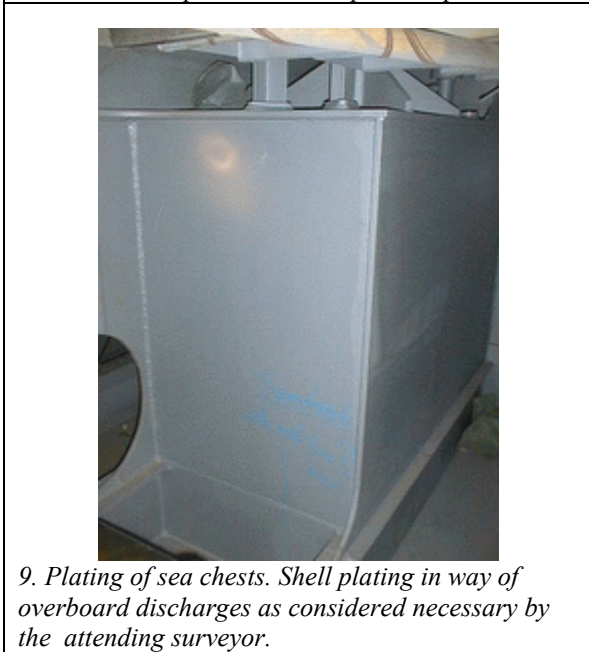

9. Plating of sea chests. Shell plating in way of overboard discharges as considered necessary by the attending surveyor.

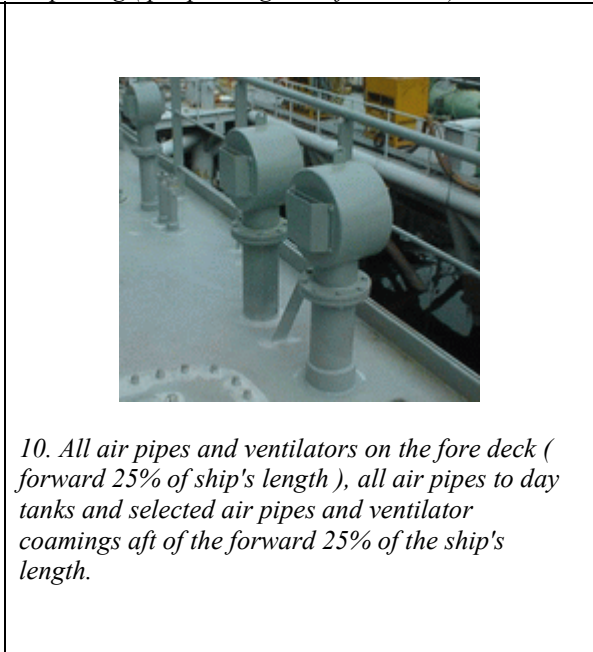

10. All air pipes and ventilators on the fore deck (forward 25% of ship's length), all air pipes to day tanks and selected air pipes and ventilator coamings aft of the forward 25% of the ship's length.

- 1) Requirements in 6.3 also apply.
- 2) For details on measurement points, see ch.7.
- 3) For ships less than 100m. in length, the number of transverse sections required at 4th. or subsequent renewal surveys may be reduced to two (2).

6.3 General dry cargo ships - Measurements i.w.o. close-up inspections
 (DNV Rules Table Pt.7 Ch.2 Table E1)

*General dry cargo carriers, measurements i.w.o. close-up - **Renewal survey No.1** (Age ~ 5 years)*

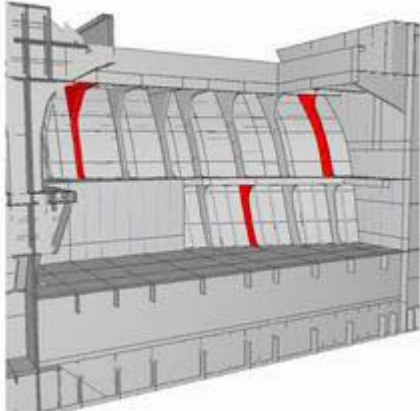

1. Selected shell frames in one forward and one aft cargo hold and associated tween deck spaces.

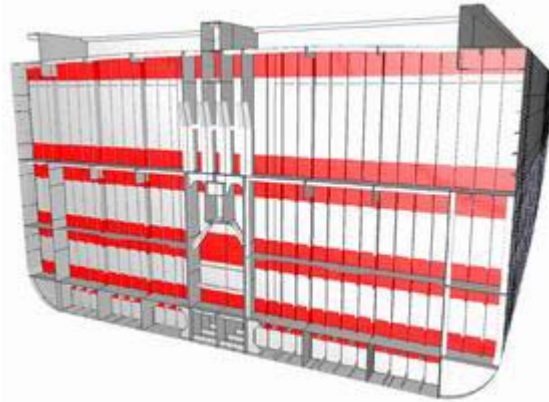

2. One selected cargo hold transverse bulkhead. See note.

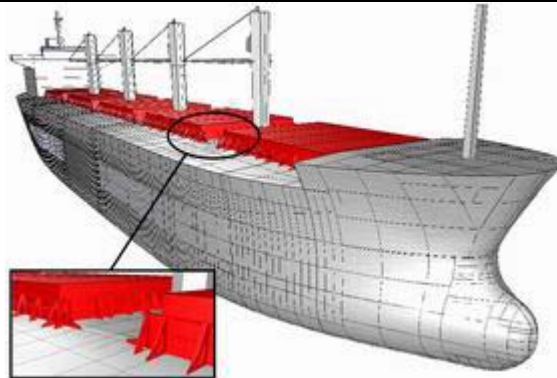

3. All cargo hold hatch covers and coamings.

- 1) Requirements in 6.2 also apply.
- 2) For details on measurement points, see ch.7.
- 3) Cargo hold transverse bulkhead to be close-up examined at the following places : Immediately above the inner bottom and immediately above the tween decks, as applicable. About mid-height of the bulkheads for holds without tween decks. Immediately below the main deck and immediately below the tween deck, as applicable.

*General dry cargo carriers, measurements i.w.o. close-up - **Renewal survey No.2** (Age ~ 10 years)*

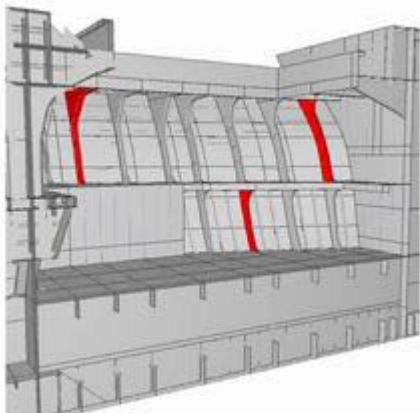

1. Selected shell frames in all cargo holds and tween deck spaces.

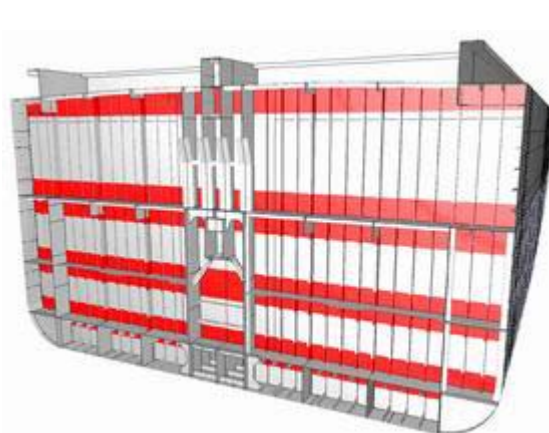

2. One transverse bulkhead in each cargo hold. See note.

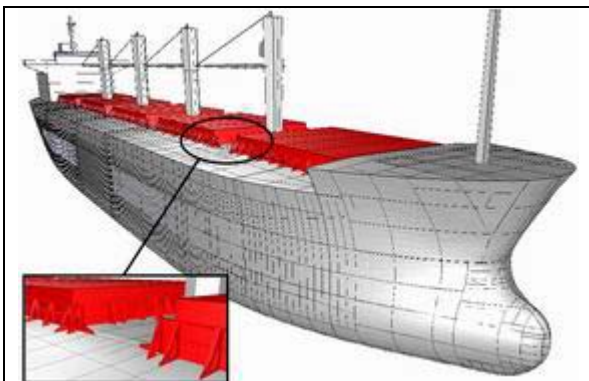

3. All cargo hold hatch covers and coamings.

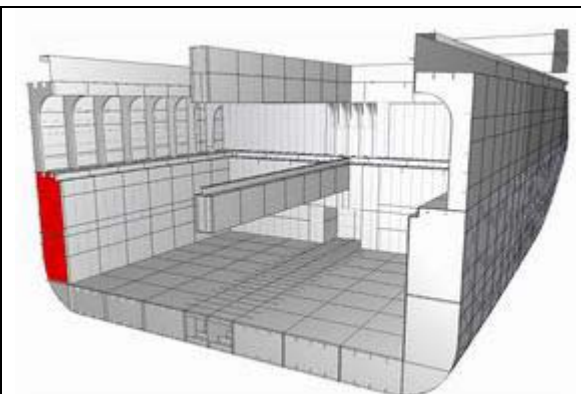

4. Forward and aft bulkhead in one side ballast tank including stiffening system.

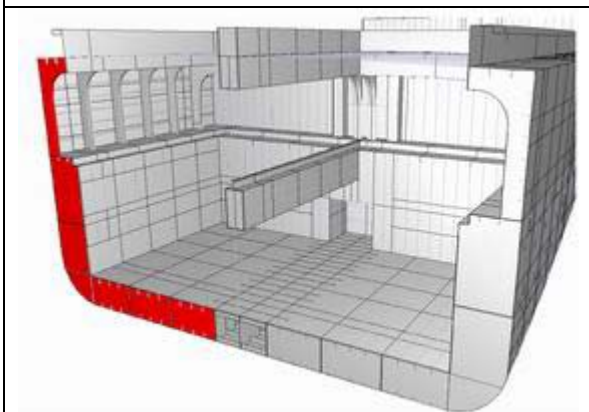

5. One transverse web with associated plating and framing in two representative ballast tanks of each type. See note 3.

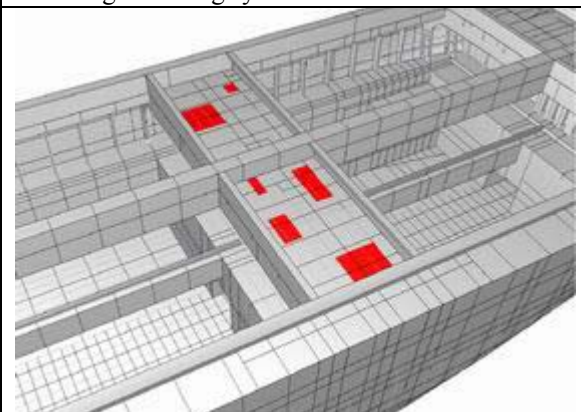

6. Selected areas of deck plating inside line of hatch openings between cargo hold hatches.

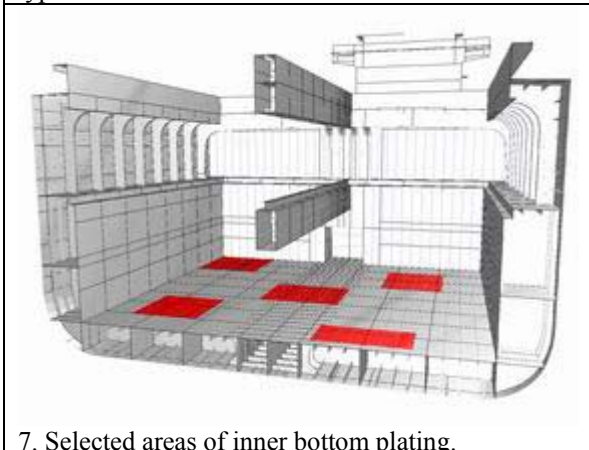

7. Selected areas of inner bottom plating.

- 1) Requirements in 6.2 also apply.
- 2) For details on measurement points, see ch.7.
- 3) Close-up examination of transverse bulkheads is to be carried out at the following levels :
 - Immediately above the inner bottom and immediately above the tween decks, as applicable.
 - About mid-height of the bulkheads for holds without tween deck.
 - Immediately below the main deck and immediately below the tween deck, as applicable.
- 4) I.e. topside, hopper side, side tank or double bottom tank. Peak tanks to be included, if applicable.

General dry cargo carriers, measurements i.w.o. close-up - Renewal survey No.3 (Age ~ 15 years)

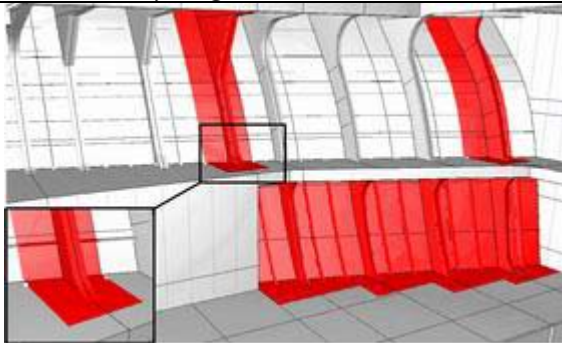

1. All shell frames in the forward lower cargo hold and 25% of shell frames in each of the remaining cargo holds and tween deck spaces including upper and lower end attachments and adjacent shell plating.

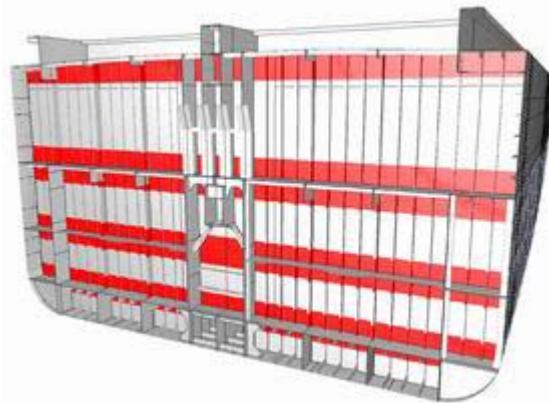

2. All cargo hold transverse bulkheads. See note 2.

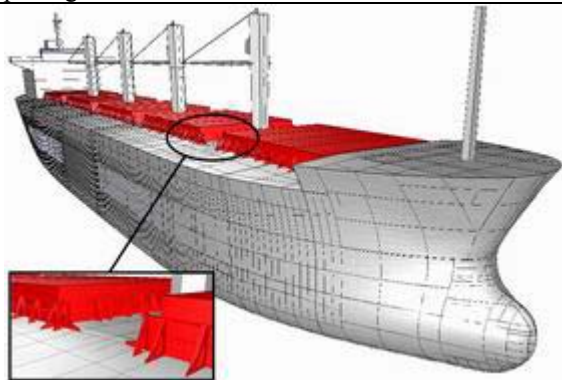

3. All cargo hold hatch covers and coamings.

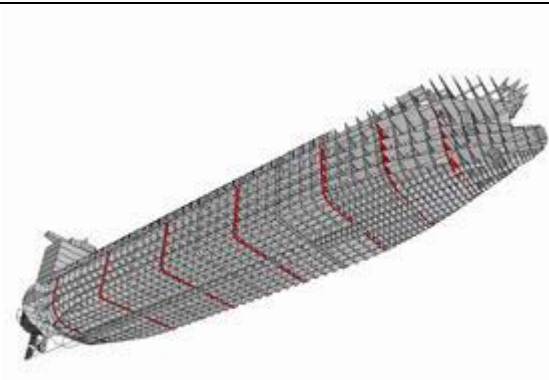

4. All transverse bulkheads in all ballast tanks, including stiffening system.

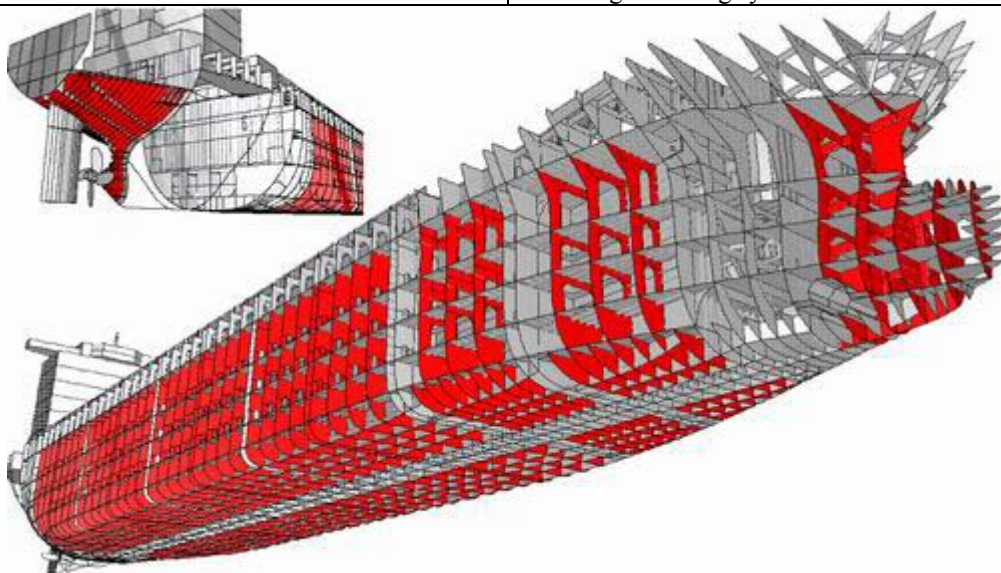

5. All transverse webs with associated plating and framing in each ballast tank.

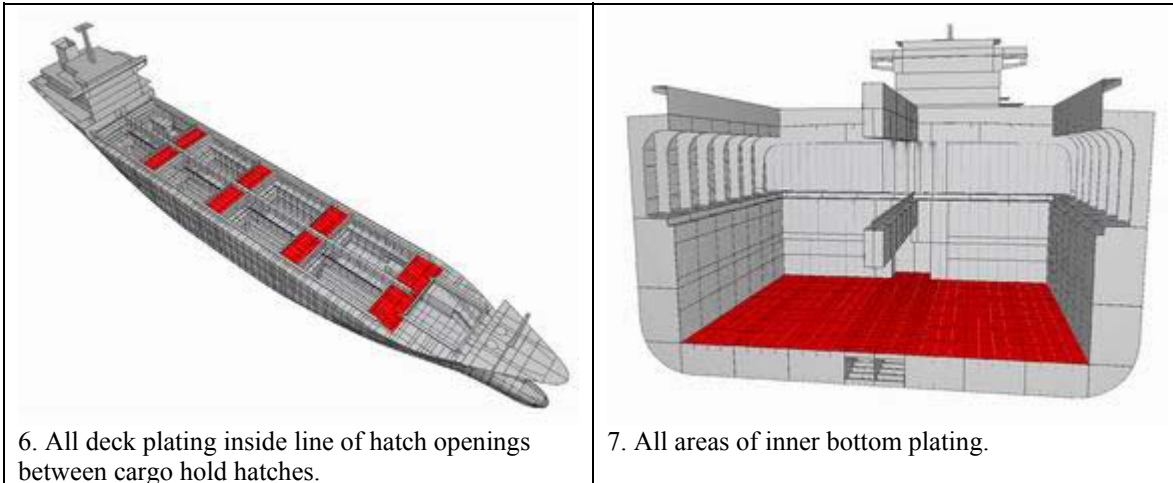

- 1) Requirements in 6.2 also apply.
- 2) For details on measurement points, see ch.7.
- 3) Close-up examination of transverse bulkheads is to be carried out at the following levels :
 - Immediately above the inner bottom and immediately above the tween decks, as applicable.
 - About mid-height of the bulkheads for holds without tween deck.
 - Immediately below the main deck and immediately below the tween deck, as applicable.
- 4) I.e. topside, hopper side, side tank or double bottom tank. Peak tanks to be included, if applicable.

*General dry cargo carriers, measurements i.w.o. close-up
- Renewal survey No.4 and subsequent (Age~20 years and more)*

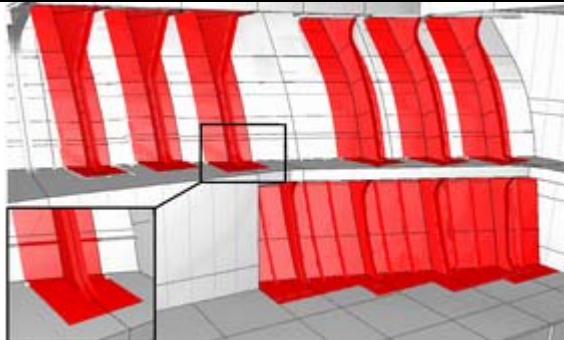

1. All shell frames in all cargo holds and tween deck spaces including upper and lower end attachments and adjacent shell plating.

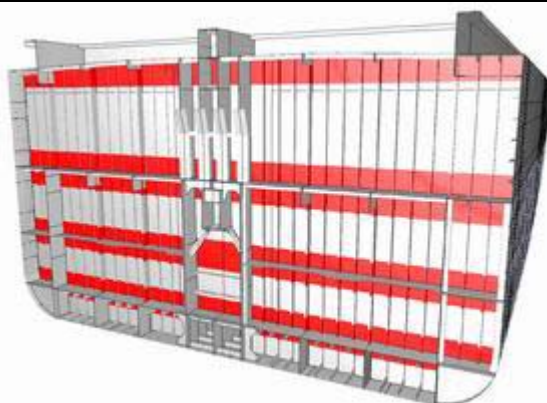

2. All cargo hold transverse bulkheads. See note. See note 2.

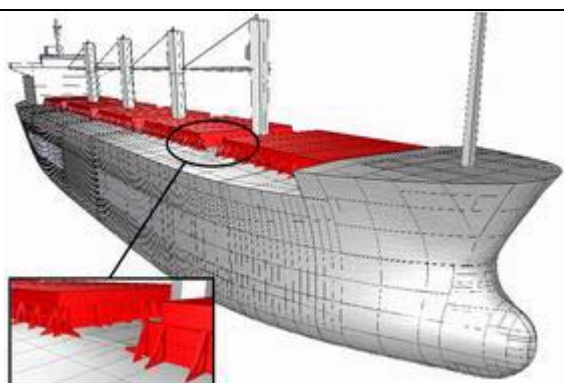

3. All cargo hold hatch covers and coamings.

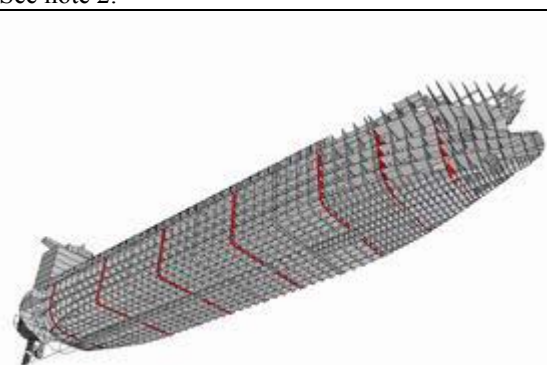

4. All transverse bulkheads in all ballast tanks , including stiffening system.

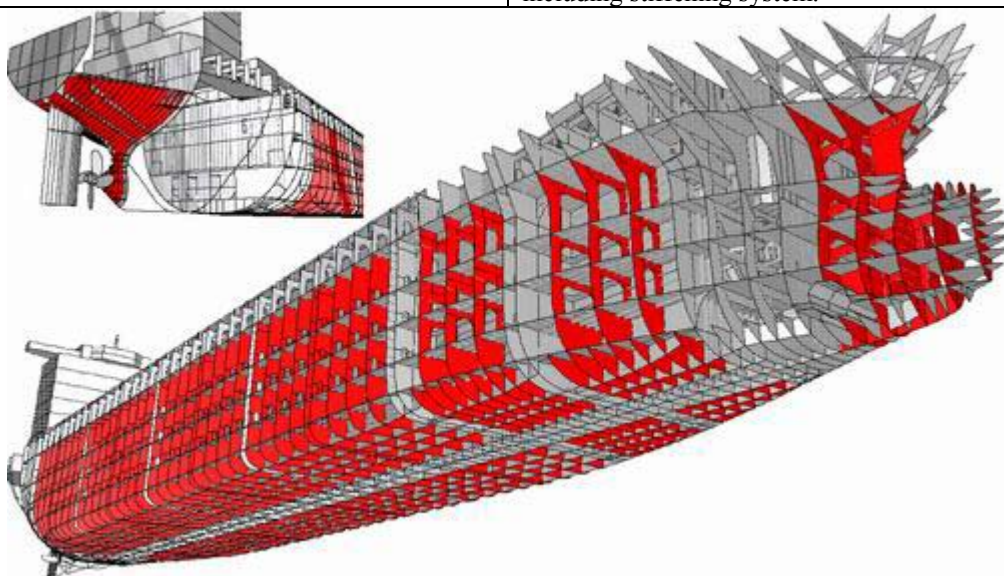

5. All transverse webs with associated plating and framing in each ballast tank. See Note 3.

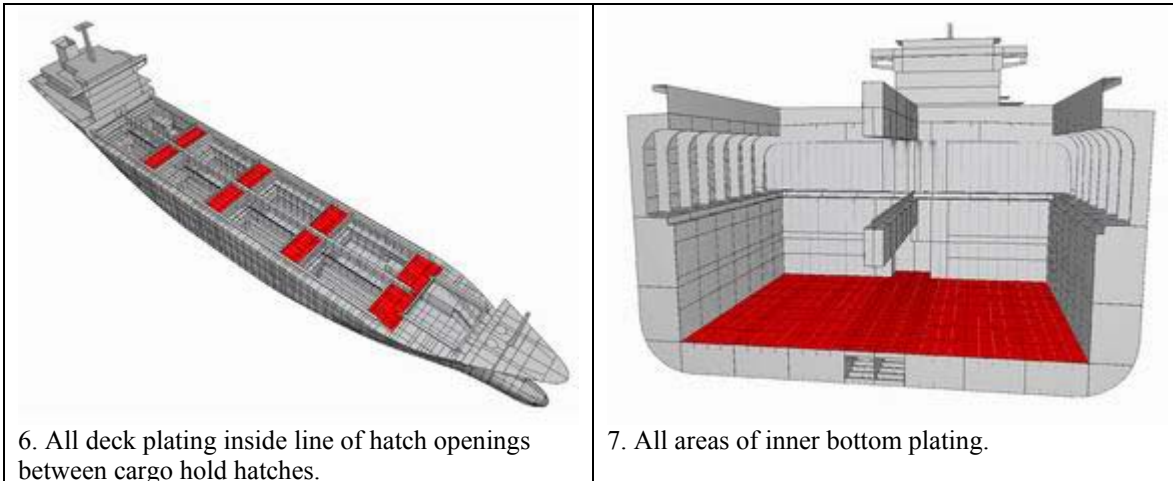

- 1) Requirements in 6.2 also apply.
- 2) For details on measurement points, see ch.7.
- 3) Close-up examination of transverse bulkheads is to be carried out at the following levels :
 - Immediately above the inner bottom and immediately above the tween decks, as applicable.
 - About mid-height of the bulkheads for holds without tween deck.
 - Immediately below the main deck and immediately below the tween deck, as applicable.
- 4) I.e. topside, hopper side, side tank or double bottom tank. Peak tanks to be included, if applicable.

6.4 Bulk carriers ESP - Systematic requirements

(DNV Rules Pt.7 Ch.2 Table F2)

- These requirements are in addition to "All Ships" requirements. Hence, the requirements in D.1 should also be done.

<i>Bulk carriers, systematic requirements - Renewal survey No.1 (Age ~5 years)</i>	
1. Suspect areas.	

<i>Bulk carriers, systematic requirements - Renewal survey No.2 (Age ~ 10 years)</i>	
1. Suspect areas	3. Measurements, for general assessment and recording of corrosion pattern, of those structural members subject to close-up examination. See 6.5. Additional requirements for extent of measurements are given in Rules. Pt.7 Ch.2 Sec.3 F500 to F700.

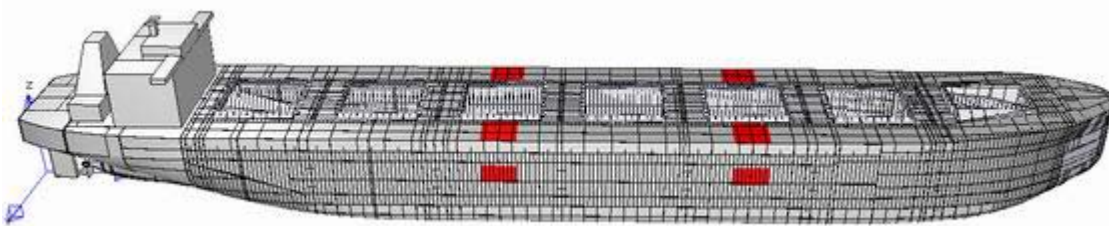

- 2. Within the cargo length area : Two transverse sections of deck plating outside line of cargo hatch openings.
- 4. Wind and water strakes (side shell plating between ballast and fully loaded water line) in way of the transverse sections considered under 2.

- 1) Requirements in 6.5 also apply.
- 2) For details on measurement points, see ch.7.

<i>Bulk carriers, systematic requirements - Renewal survey No.3 (Age ~ 15 years)</i>	
1. Suspect areas	3. Measurements, for general assessment and recording of corrosion pattern, of those structural members subject to close-up examination. See 6.5.

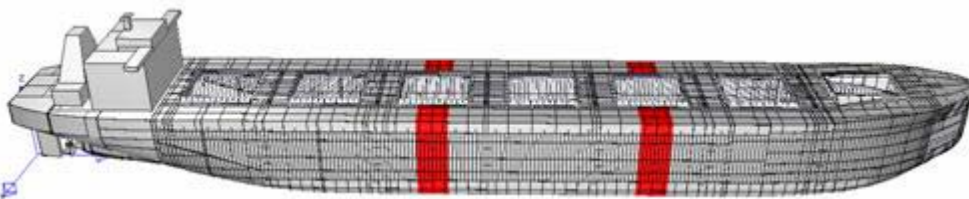

- 2. Two transverse sections, whereof one in the amidship area, outside line of cargo hatch openings.

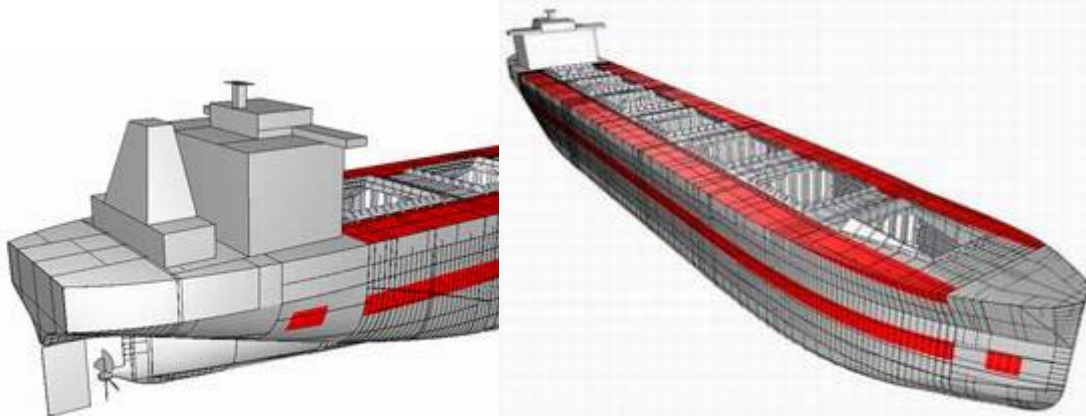

- 4. All wind and water strakes (side shell plating between ballast and fully loaded water line) within the cargo length area. Selected wind and water strakes outside the cargo length area.
- 5. Each deck plate outside line of cargo hatch openings within the cargo length area.

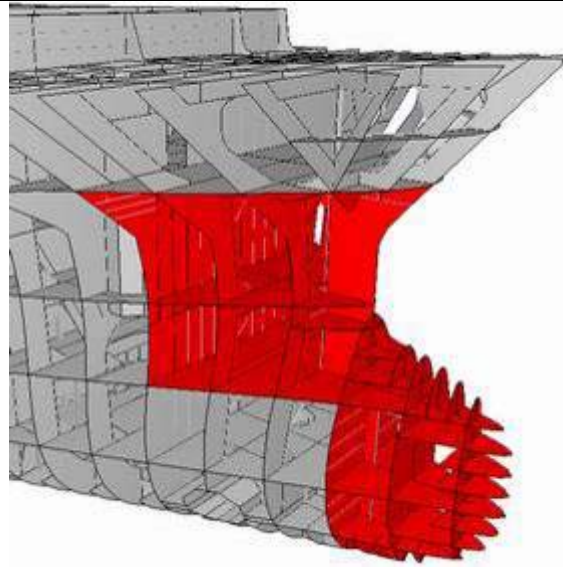

9. Internals in forepeak tank.



11. All air pipes and ventilators on the fore deck (forward 25% of ship's length), all air pipes to day tanks and selected air pipes and ventilator coamings aft of the forward 25% of the ship's length.

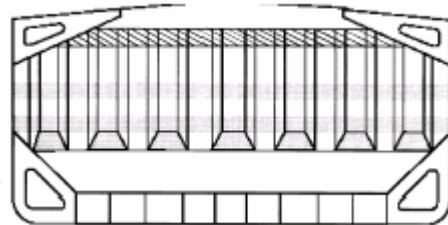

12. Bulk carriers fitting the description given in Pt.7 Ch.1 Sec.6 E100, should have additional measurements of the transverse bulkhead between cargo hold no.1 and cargo hold no.2, as detailed in Rules Pt.7 Ch.2 Sec.3 F500. A figure with measurement points is given in the Rules.

- 1) Requirements in 6.5 also apply.
- 2) For details on measurement points in 2-5, see ch.7.

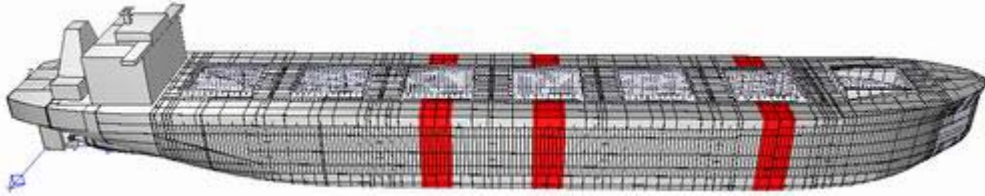
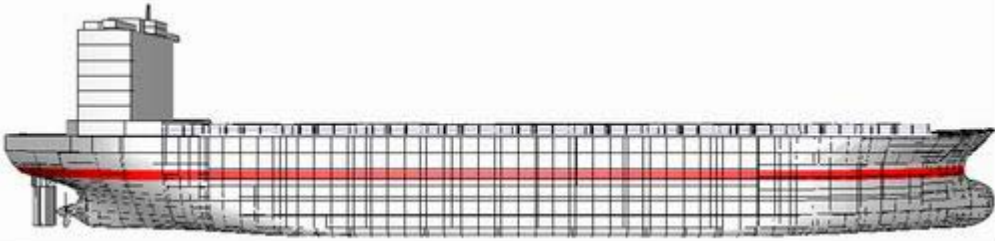
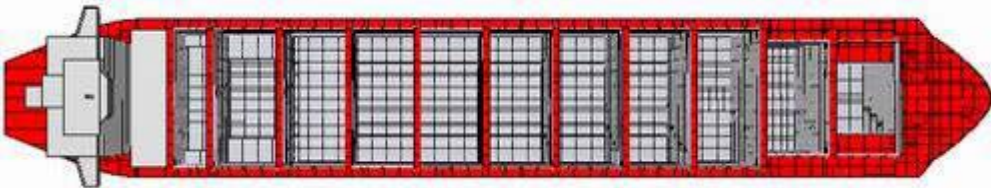
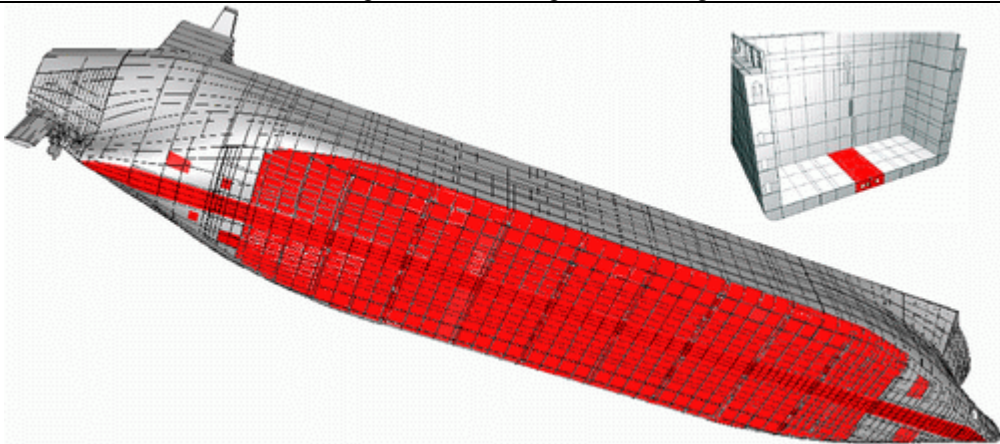
<i>Bulk carriers, systematic requirements - Renewal survey No.4 and subsequent surveys (Age ~ 20 years)</i>	
1. Suspect areas	3. Measurements, for general assessment and recording of corrosion pattern, of those structural members subject to close-up examination. See 6.5.
	
2. Within the cargo length area : Three transverse sections, whereof one in the amidship area, outside line of cargo hatch openings.	
	
4. All wind and water strakes (side shell plating between ballast and fully loaded water line) full length of the ship.	
	
5. All exposed main deck plates full length.	
	
6. Each bottom plate, including lower turn of bilge, within the cargo length area. 7. Duct keel or pipe tunnel plating and internals within the cargo length area. All keel plates full length. Selected bottom plates in way of cofferdams, machinery space and tanks outside cargo length area.	



8. Plating of sea chests. Shell plating in way of overboard discharges as considered necessary by the attending surveyor.

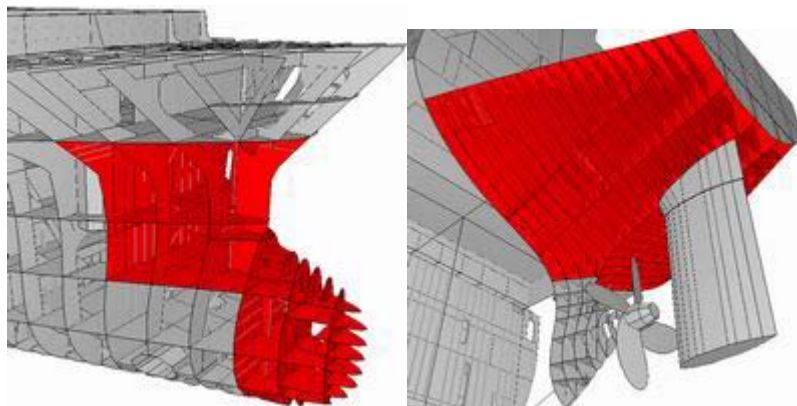

9. Internals in forepeak tank and after peak tank.

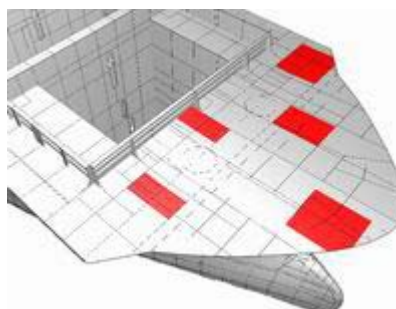
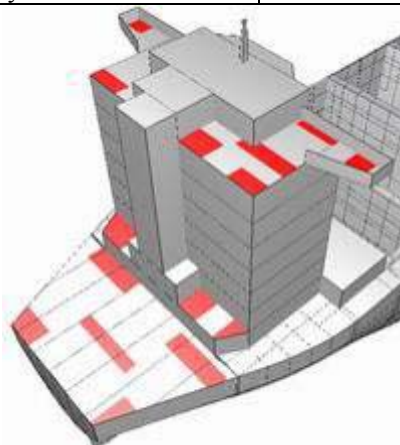

10. Representative, exposed superstructure deck plating (poop, bridge and forecastle).



11. All air pipes and ventilators on the fore deck (forward 25% of ship's length), all air pipes to day tanks and selected air pipes and ventilator coamings aft of the forward 25% of the ship's length.

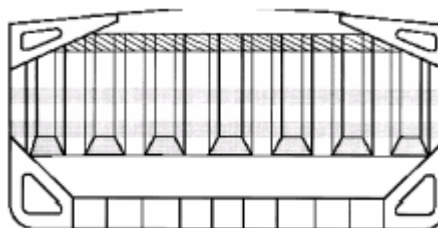

12. Bulk carriers fitting the description given in Pt.7 Ch.1 Sec.6 E100, should have additional measurements of the transverse bulkhead between cargo hold no.1 and cargo hold no.2, as detailed in Rules Pt.7 Ch.2 Sec.3 F500. A figure with measurement points is given in the Rules.

- 1) Requirements in 6.5 also apply.
- 2) For details on measurement points, see ch.7.

6.5 Bulk carriers ESP - Measurements i.w.o. close-up inspections
 (DNV Rules Pt.7Ch.2 Sec.3 Table F1)

Bulk carriers, measurements i.w.o. close-up - Renewal survey No.1 (Age ~ 5 years)

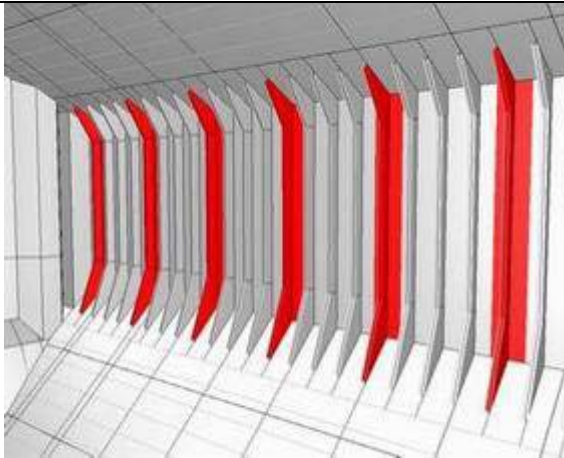

1. 25% of frames in the forward cargo hold at representative positions.
 Selected frames in remaining cargo holds.

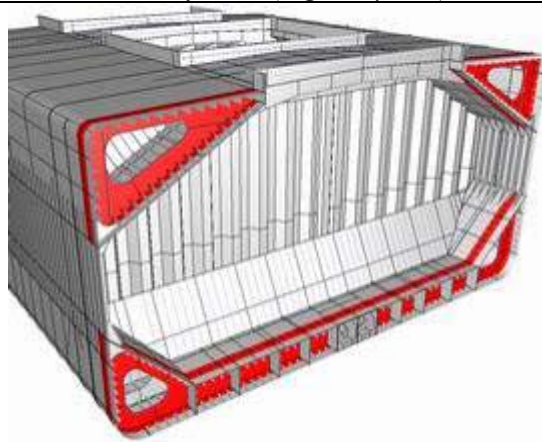

2. One transverse web with associated plating and longitudinals in two representative ballast tanks of each type (i.e. topside, hopper side or side tank).

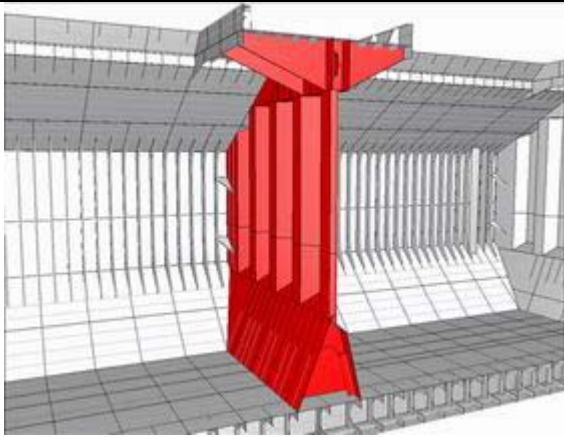

3. Two selected cargo hold transverse bulkheads, including internal structure of upper and lower stools, where fitted.

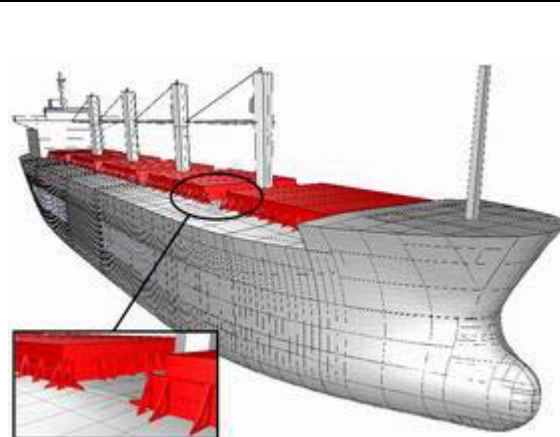

4. All cargo hold hatch covers and coamings.

- 1) Requirements in 6.4 also apply.
- 2) For details on measurement points, see ch.7.

Bulk carriers, measurements i.w.o. close-up - Renewal survey No.2 (Age ~ 10 years)

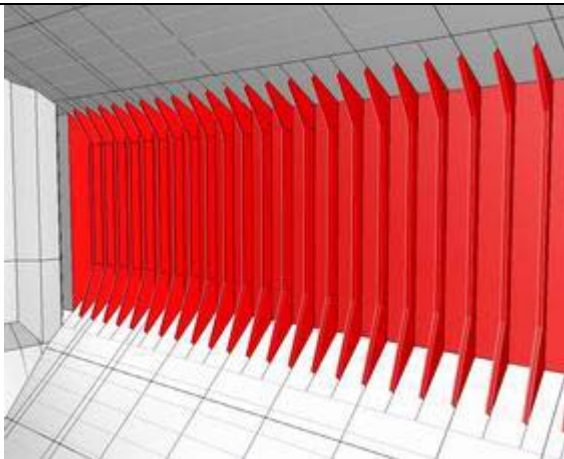

1. a) All shell frames in the forward cargo hold, including upper and lower end attachments and

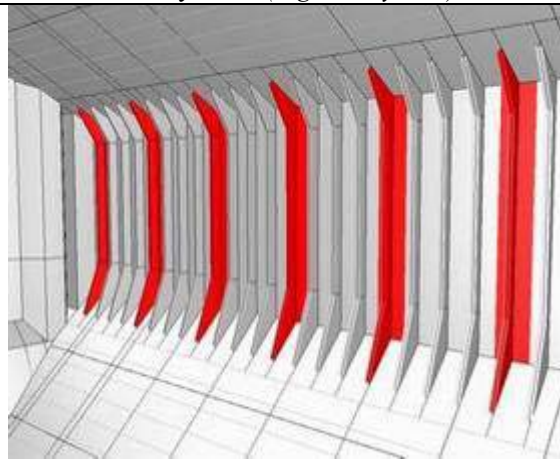

1. b) 25% of shell frames in all other cargo holds, including upper and lower end attachments and

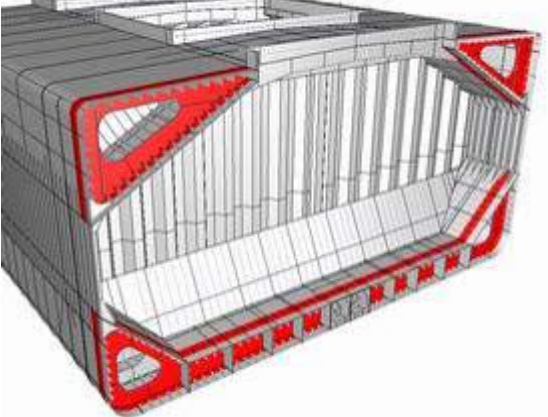
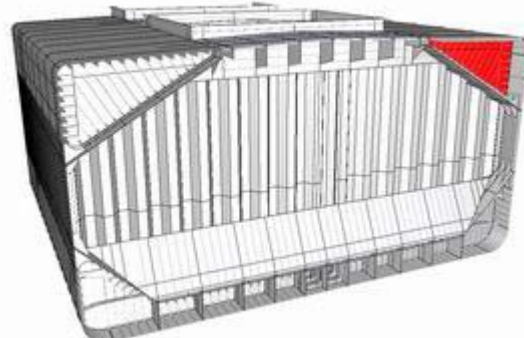
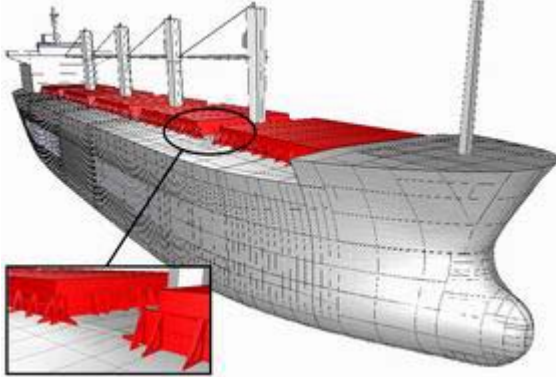
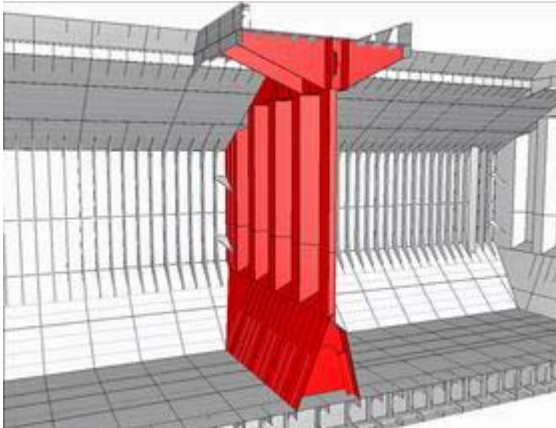
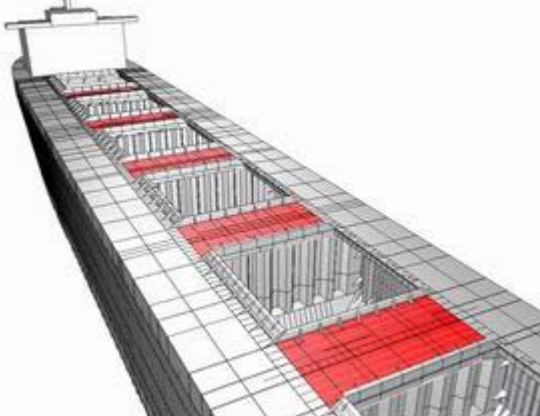
<p>adjacent shell plating.</p>  <p>2. One transverse web with associated plating and longitudinals in each ballast tank (i.e. topside, hopper side or side tank).</p>	<p>adjacent shell plating.</p>  <p>3. Forward and aft transverse bulkhead in one side ballast tank, including stiffening system.</p>
 <p>4. All cargo hold hatch covers and coamings.</p>	 <p>5. All cargo hold transverse bulkheads, including internal structure of upper and lower stools, where fitted.</p>
 <p>6. All deck plating and under deck structure inside line of hatch openings between all cargo hold hatches.</p> <p>1) Requirements in 6.4 also apply. 2) For details on measurement points, see ch.7.</p>	

Bulk carriers, measurements i.w.o. close-up - Renewal survey No.3 (Age ~ 15 years)

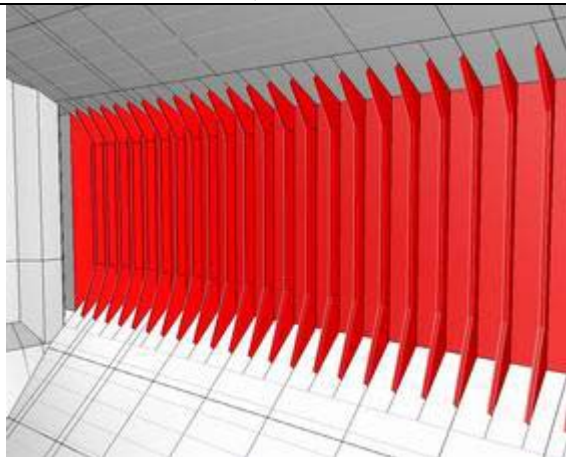

1. a) All shell frames in the forward cargo hold, including upper and lower end attachments and adjacent shell plating.

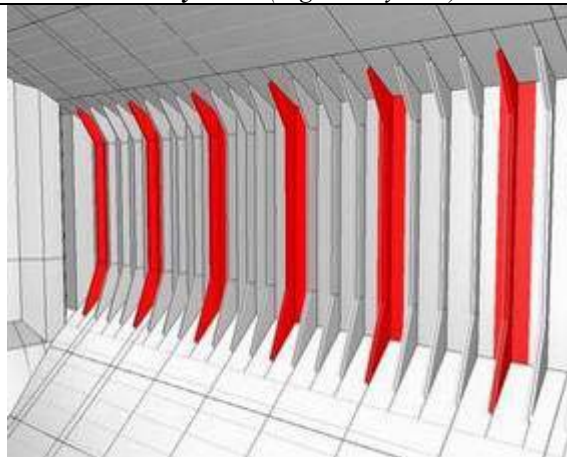

1. b) 25% of shell frames in all other cargo holds, including upper and lower end attachments and adjacent shell plating.

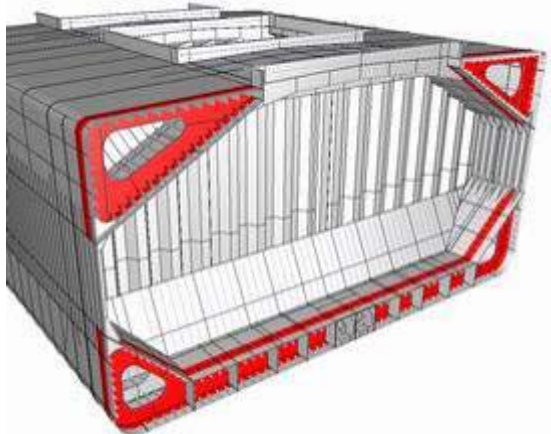

2. All transverse webs with associated plating and longitudinals in each ballast tank (i.e. topside, hopper side or side tank).

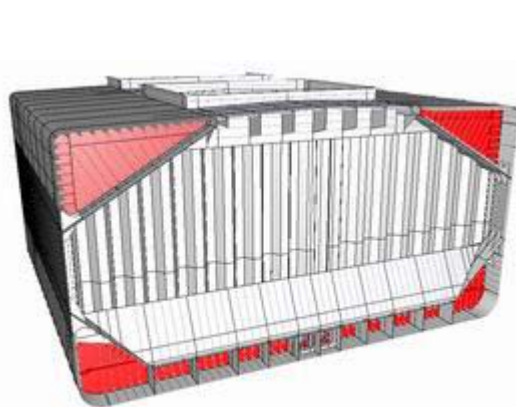

3. All transverse bulkheads in ballast tanks, including stiffening system.

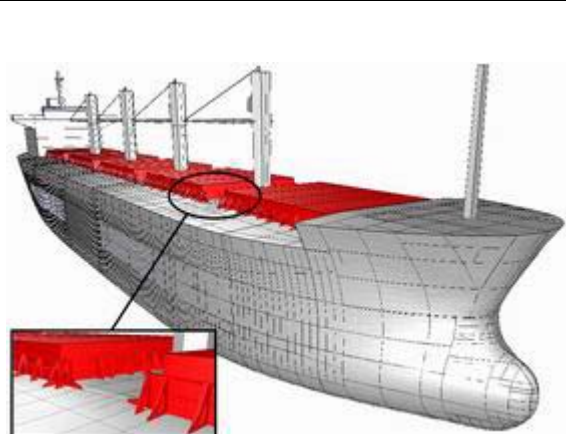

4. All cargo hold hatch covers and coamings.

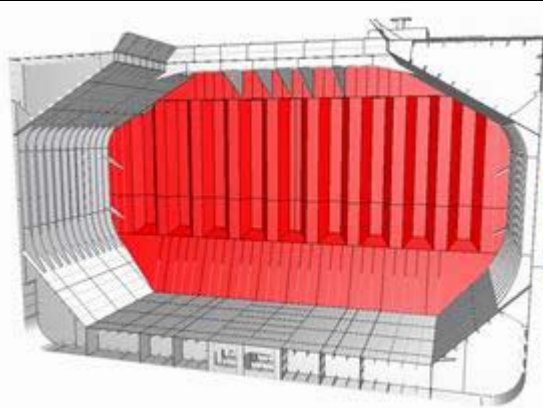

5. All cargo hold transverse bulkheads, including internal structure of upper and lower stools, where fitted.

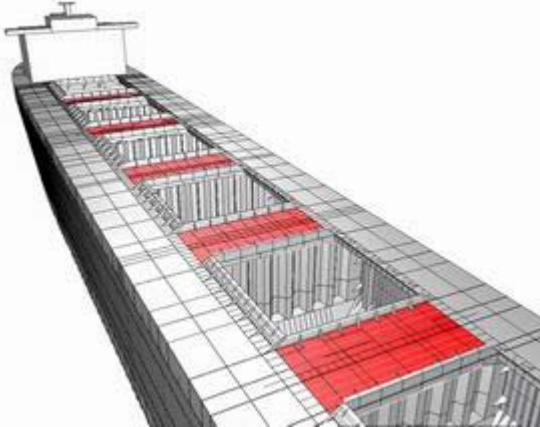
 <p>6. All deck plating and under deck structure inside line of hatch openings between all cargo hold hatches.</p>	
---	--

- 1) Requirements in 6.4 also apply.
- 2) For details on measurement points, see ch.7.

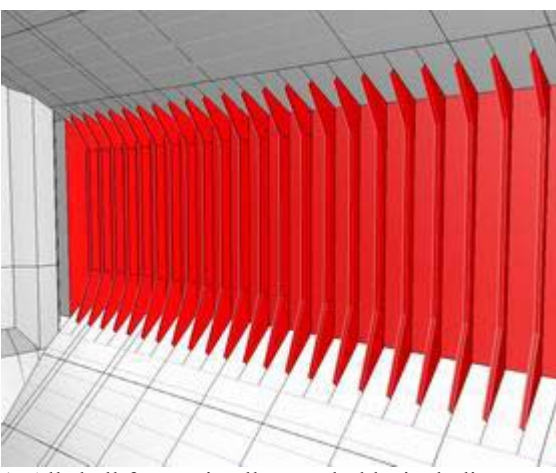
<p><i>Bulk carriers, measurements i.w.o. close-up - Renewal survey No.4 and subsequent (Age ~ 20 years and more)</i></p>	
 <p>1. All shell frames in all cargo holds, including upper and lower end attachments and adjacent shell plating.</p>	<p>Items 2 to 6 as for Renewal survey No.3.</p>

- 1) Requirements in 6.4 also apply.
- 2) For details on measurement points, see ch.7.

6.6 All ESP Tankers- Systematic requirements

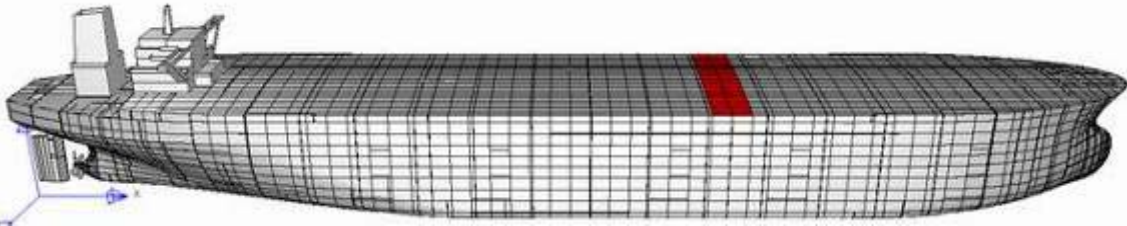

(DNV Rules Pt.7 Ch.2 Tables G3, G4 and K2)

- The systematic requirements for single and double hull oil tankers, ore/oil ships, as well as chemical tankers, are very similar. Where there's a difference between the three, that is noted in particular under the corresponding figure in the following tables. The close-up requirements with corresponding thickness measurements, are a bit more different, and have been put in different tables, namely D.5 and D.6.

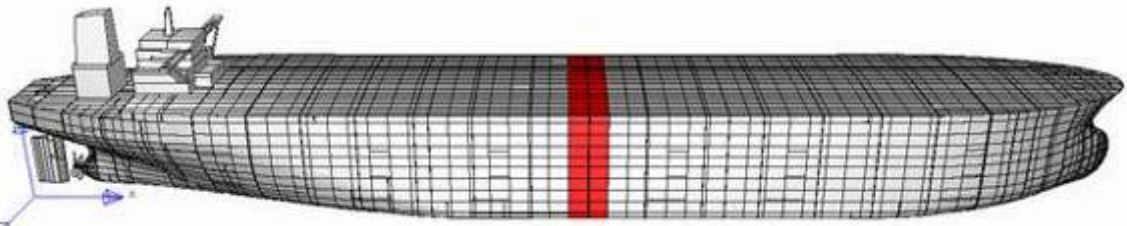
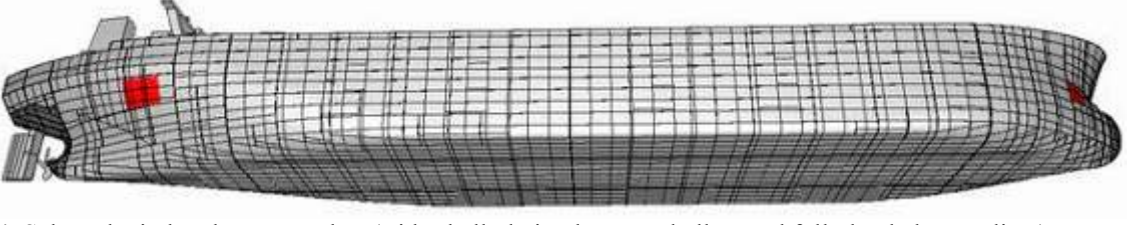
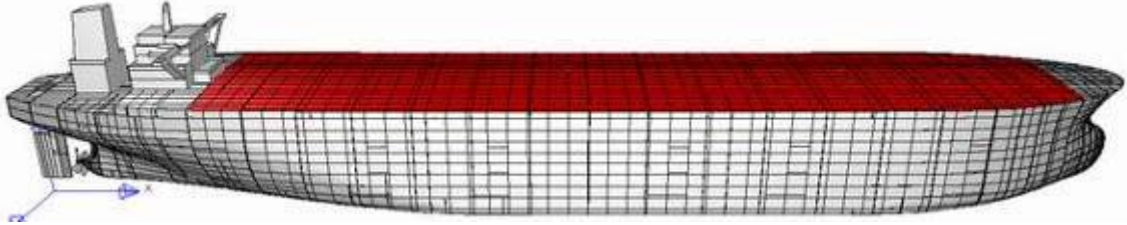
<i>Tankers, systematic requirements - Renewal survey No.1 (Age ~5 years)</i>	
1. Suspect areas.	3. Measurements, for general assessment and recording of corrosion pattern, of those structural members subject to close-up examination (See 6.7, 6.8 or 6.9).
	
2. One section of deck plating for the full beam of the ship within the cargo length area (in way of a ballast tank, if any, or a cargo tank used primarily for water ballast).	
1) Requirements in 6.7, 6.8 or 6.9 also apply, depending on ship type. 2) For details on measurement points, see ch.7.	

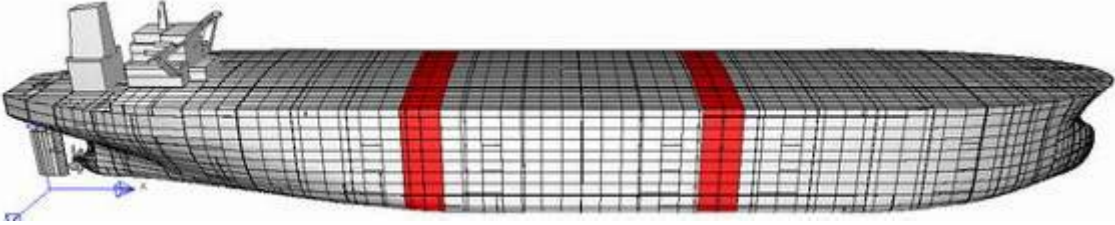
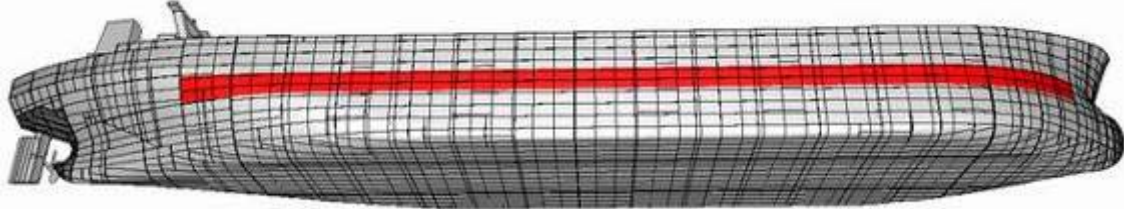
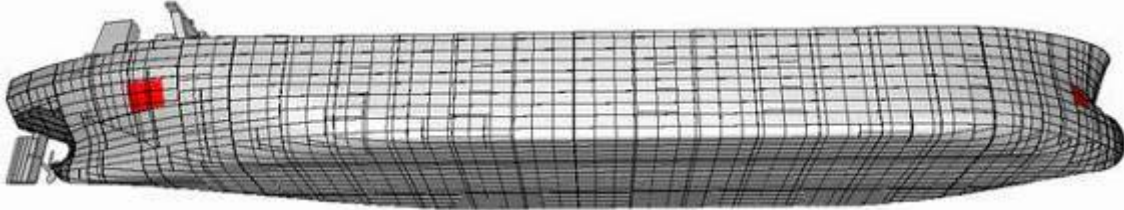
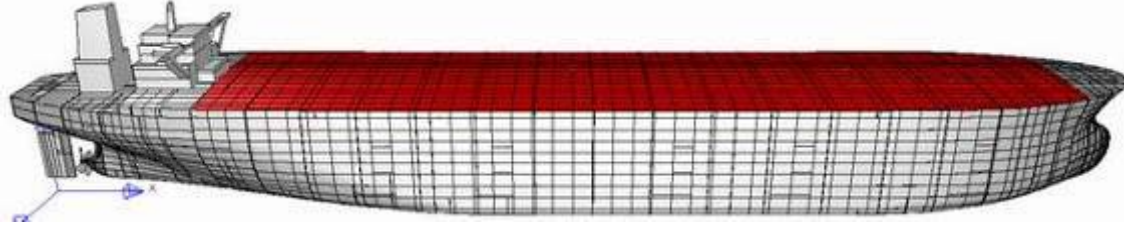
<i>Tankers, systematic requirements - Renewal survey No.2 (Age ~10 years)</i>	
1. Suspect areas.	3. Measurements, for general assessment and recording of corrosion pattern, of those structural members subject to close-up examination (See 6.7, 6.8 or 6.9).
	
2. Within the cargo area : One transverse section.	
	
4. Selected wind and water strakes (side shell plating between ballast and fully loaded water line) outside the cargo area.	
	
5. Each deck plate within the cargo area.	
1) Requirements in 6.7, 6.8 or 6.9 also apply, depending on ship type. 2) For details on measurement points, see ch.7.	

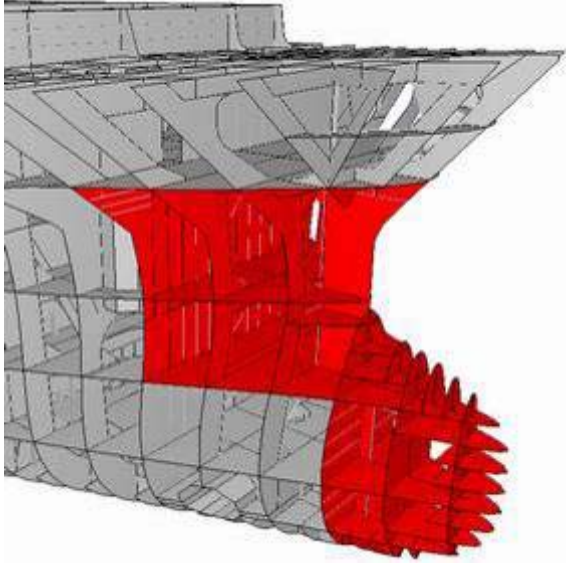
<i>Tankers, systematic requirements - Renewal survey No.3 (Age ~15 years)</i>	
1. Suspect areas.	3. Measurements, for general assessment and recording of corrosion pattern, of those structural members subject to close-up examination (See 6.7, 6.8 or 6.9).
	
2. Within the cargo area : Two transverse sections. (At least one section should be within 0.5L amidships).	
	
4.a) All wind and water strakes (side shell plating between ballast and fully loaded water line) within the cargo area.	
	
4.b) Selected wind and water strakes (side shell plating between ballast and fully loaded water line) outside the cargo area.	
	
5. Each deck plate within the cargo area.	

	 <p>11. All air pipes and ventilators on the fore deck (forward 25% of ship's length), all air pipes to day tanks and selected air pipes and ventilator coamings aft of the forward 25% of the ship's length.</p>
---	---

9. Internals in forepeak tank.

- 1) Requirements in 6.7, 6.8 or 6.9 also apply, depending on ship type.
- 2) For details on measurement points, see ch.7.
- 3) The numbering of the requirements follow the numbering in the rules Pt.7 Ch.2, and is not necessarily sequential (1,2,3..).

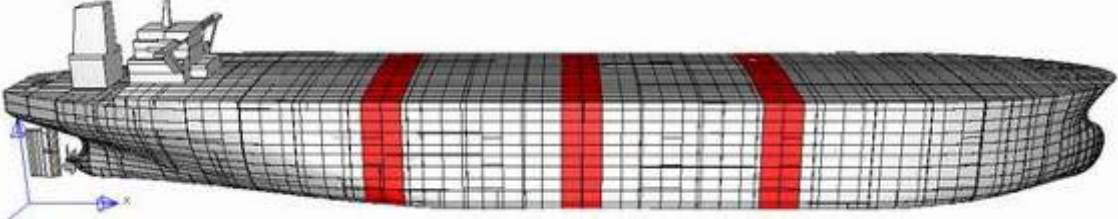
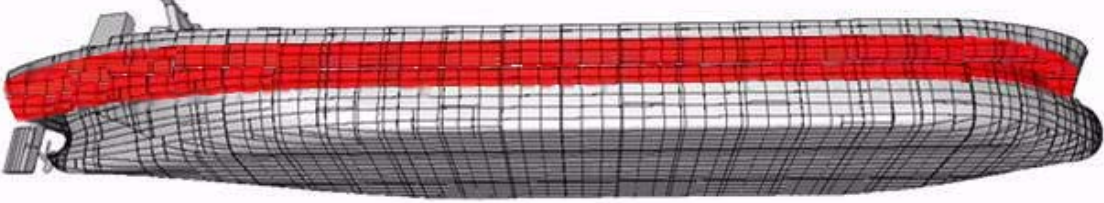
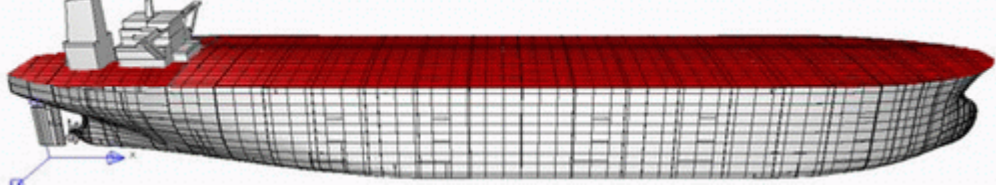
<i>Tankers, systematic requirements - Renewal survey No.4 and subsequent (Age ~20 years and more)</i>	
<p>1. Suspect areas.</p>	<p>3. Measurements, for general assessment and recording of corrosion pattern, of those structural members subject to close-up examination (See 6.7, 6.8 or 6.9).</p>
 <p>2. Within the cargo area : Three transverse sections. At least one section should be within 0.5L.</p>	
 <p>4. All wind and water strakes (side shell plating between ballast and fully loaded water line), full length of the ship.</p>	
 <p>5. All exposed main deck plates full length.</p>	

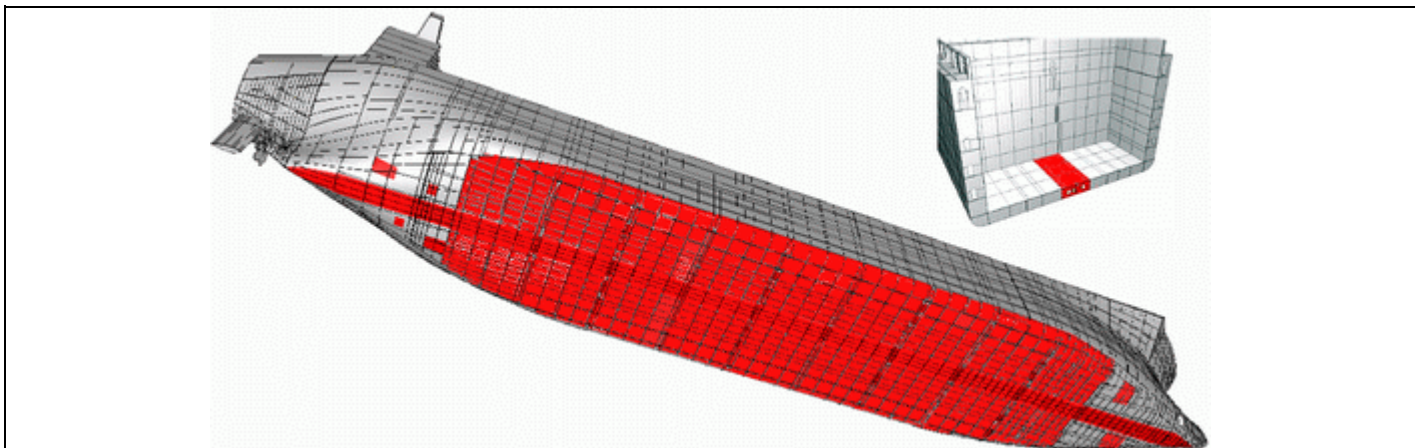

- 6. Each bottom plate, including lower turn of bilge, within the cargo length area.
- 7. Duct keel or pipe tunnel plating and internals within the cargo length area. All keel plates full length, selected bottom plates in way of cofferdams, machinery space and tanks outside cargo length area.



8. Plating of sea chests. Shell plating in way of overboard discharges as considered necessary by the attending surveyor.

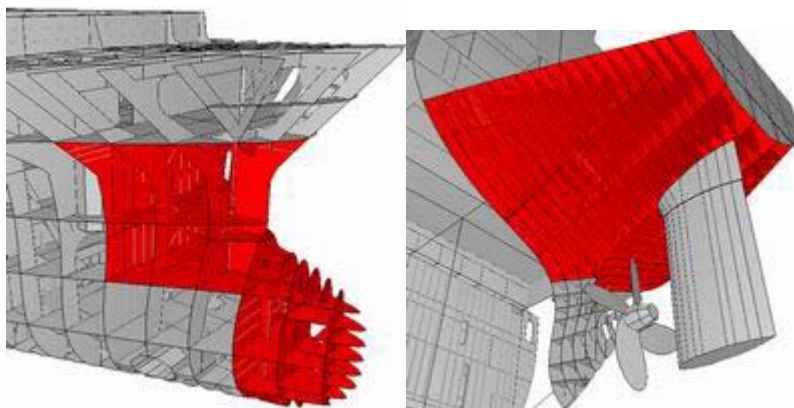

9. Internals in forepeak tank and after peak tank.

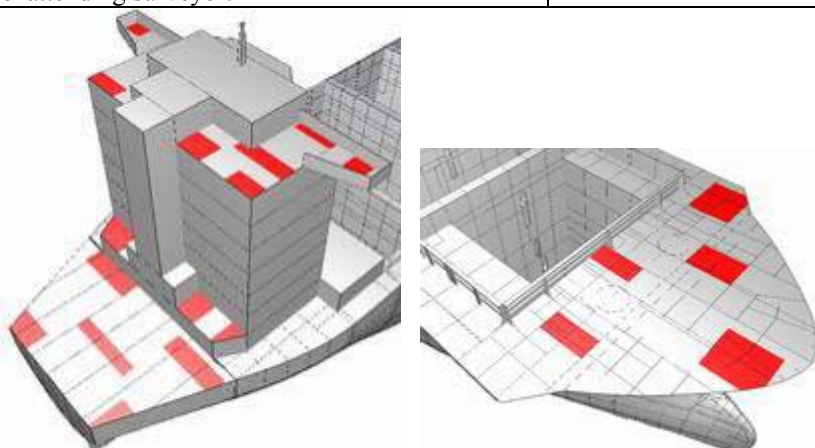

10. Representative exposed superstructure deck plating (poop, bridge and forecastle deck).



11. All air pipes and ventilators on the fore deck (forward 25% of ship's length), all air pipes to day tanks and selected air pipes and ventilator coamings aft of the forward 25% of the ship's length.

- 1) Requirements in 6.7, 6.8 or 6.9 also apply, depending on ship type.
- 2) For details on measurement points, see ch.7.

6.7 Single Hull Oil Tankers, Ore/Oil Ships ESP - Measurements i.w.o. close-up inspections
 (DNV Rules Pt.7 Ch.2 Sec.3 Table G1)

*Single Hull Oil Tankers, Ore/Oil Ships, measurements i.w.o. close-up - **Renewal survey No.1** (Age ~ 5 years)*

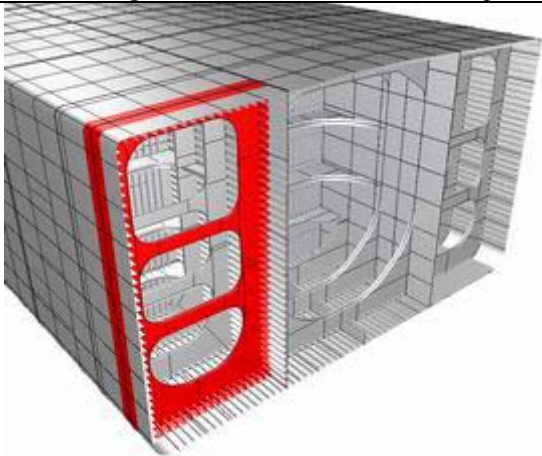

1. One web frame ring - in a ballast wing tank, if any, or a cargo wing tank used primarily for water ballast.

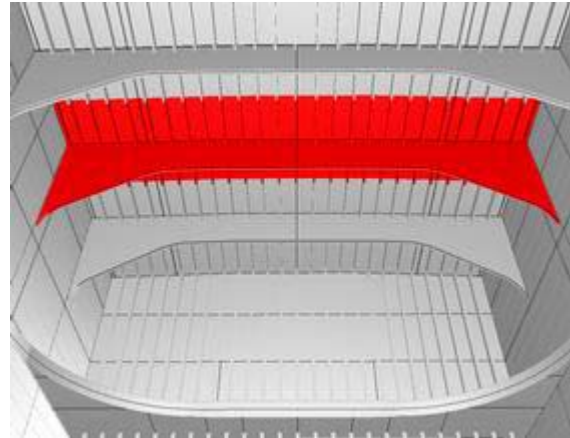

3. One deck transverse in a cargo oil tank.

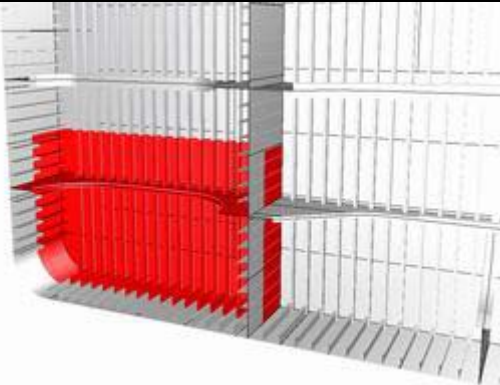

6. Lower part of one transverse bulkhead in a ballast tank.

8. Lower part of one transverse bulkhead in a cargo oil wing tank.

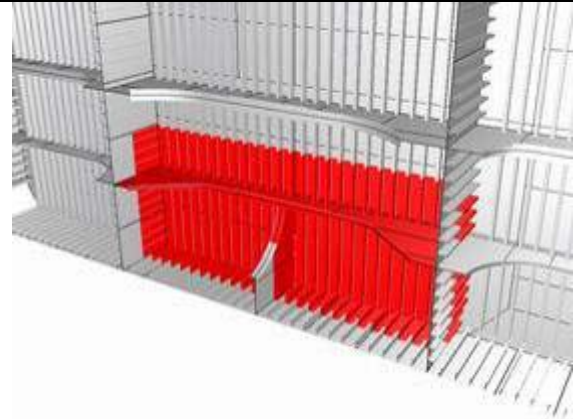

9. Lower part of one transverse bulkhead in a cargo oil centre tank.

- 1) Requirements in 6.6 also apply.
- 2) For details on measurement points, see ch.7.
- 3) The numbering of the requirements follow the numbering in the rules Pt.7 Ch.2, and is not necessarily sequential (1,2,3..).
- 4) Web frame rings shall be complete, including adjacent structural members.
- 5) The deck transverse shall include adjacent structural members.

*Single Hull Oil Tankers, Ore/Oil Ships, measurements i.w.o. close-up
- Renewal survey No.2 (Age ~ 10 years)*

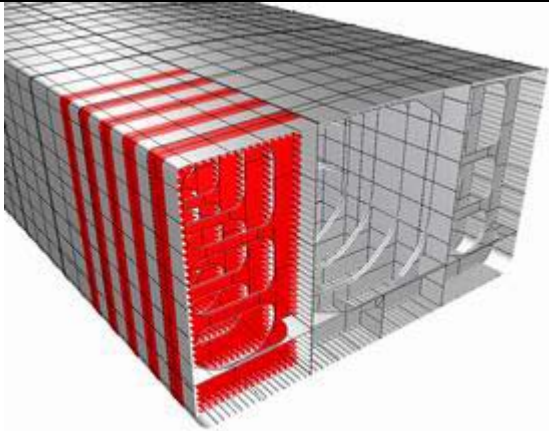

1. All web frame rings - in a ballast wing tank, if any, or a cargo wing tank used primarily for water ballast.

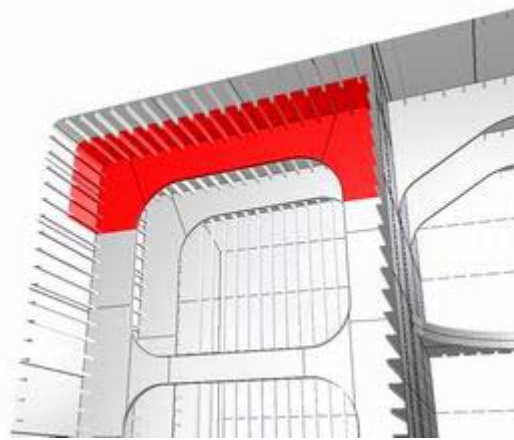

2. One deck transverse in each of the remaining ballast tanks, if any.
3. One deck transverse in a cargo wing tank.

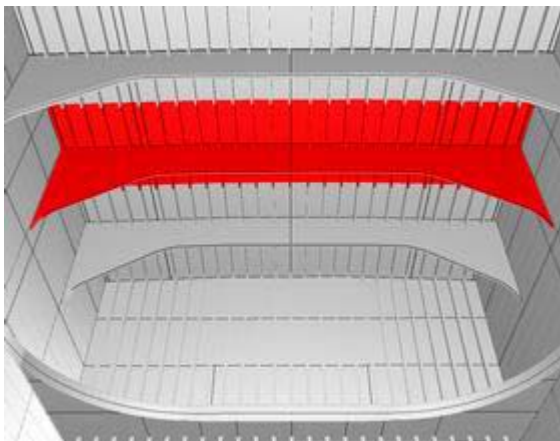

5. One deck transverse, in two cargo centre tanks.

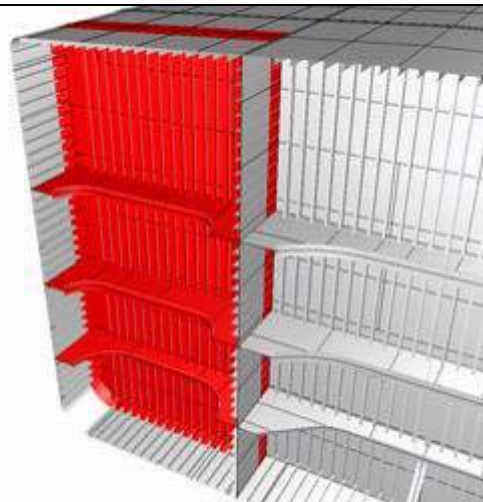

6. Both transverse bulkheads - in a wing ballast tank, if any, or a cargo wing tank used primarily for water ballast.



7. Lower part of one transverse bulkhead - in each remaining ballast tank.
8. Lower part of one transverse bulkhead - in a cargo oil wing tank.

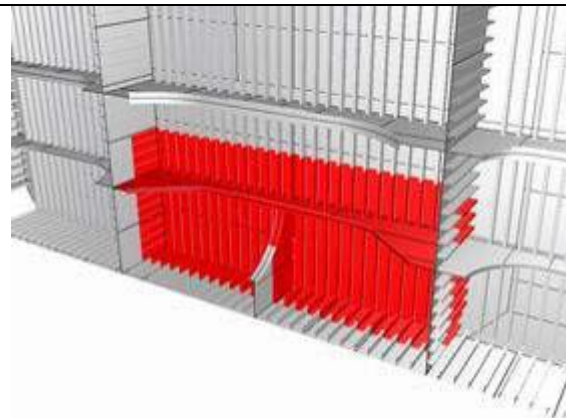

9. Lower part of one transverse bulkhead - in two cargo centre tanks.

- 1) Requirements in 6.6 also apply.
- 2) For details on measurement points, see ch.7.

- 3) The numbering of the requirements follow the numbering in the rules Pt.7 Ch.2, and is not necessarily sequential (1,2,3..).
- 4) Web frame rings, deck transverses and bulkheads shall include adjacent structural members.

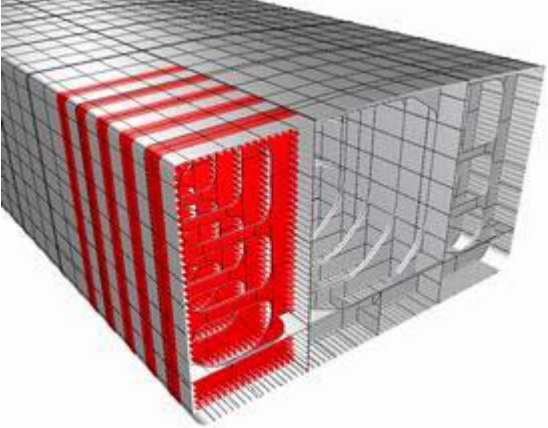
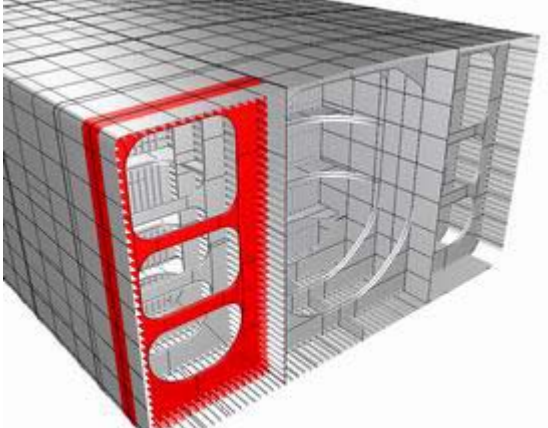
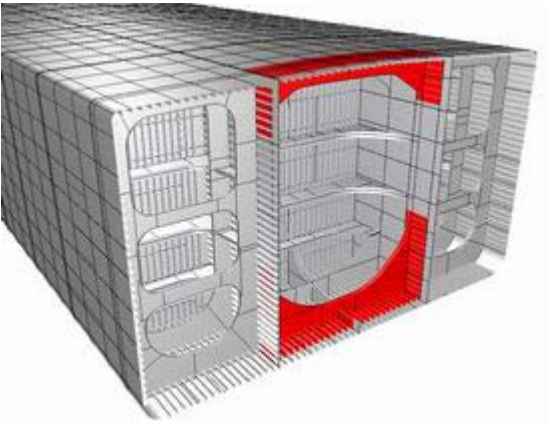
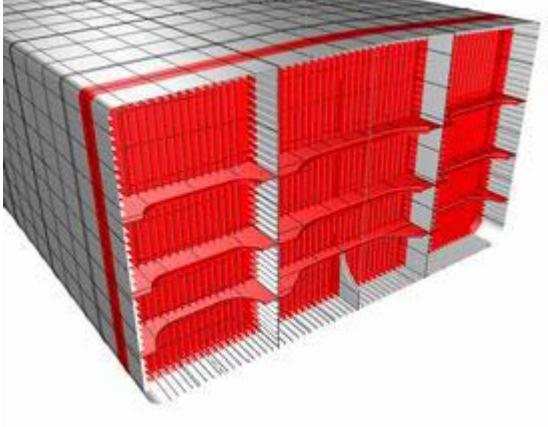
<i>Single Hull Oil Tankers, Ore/Oil Ships, measurements i.w.o. close-up - Renewal survey No.3 (Age ~ 15 years)</i>	
	
<p>1. All web frame rings - in all ballast tanks. 3. All web frame rings - in a cargo wing tank.</p>	<p>4. 30% (minimum 3) of web frame rings - in each remaining cargo wing tank.</p>
	
<p>5. 30% (minimum 3) of deck and bottom transverses - in each cargo centre tank.</p>	<p>6. All transverse bulkheads - in all cargo and ballast tanks.</p>
<p>10. As considered necessary by the surveyor.</p>	

- 1) Requirements in 6.6 also apply.
- 2) For details on measurement points, see ch.7.
- 3) The numbering of the requirements follow the numbering in the rules Pt.7 Ch.2, and is not necessarily sequential (1,2,3..).
- 4) Web frame rings, deck transverses and bulkheads shall include adjacent structural members.

Single Hull Oil Tankers, Ore/Oil Ships, measurements i.w.o. close-up - Renewal survey No.4 and subsequent (Age ~ 20 years or more) - As Renewal survey No.3.

6.8 Double Hull Oil Tankers, Ore/Oil Ships ESP - Measurements i.w.o. close-up inspections
(DNV Rules Pt.7 Ch.2 Table G2)

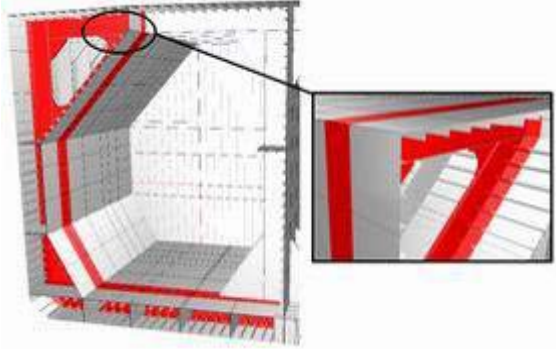
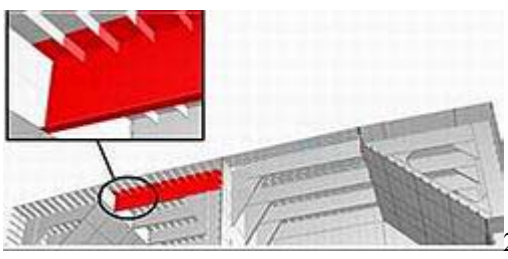
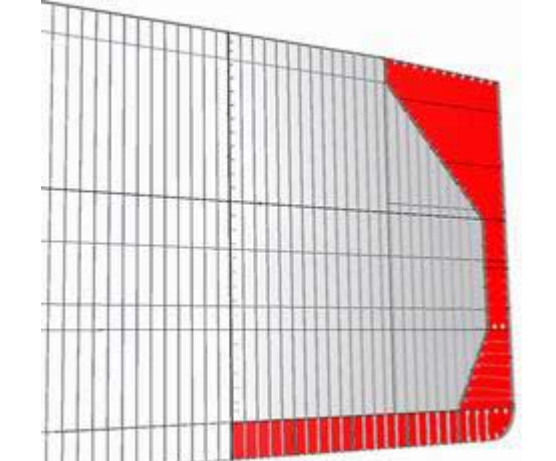
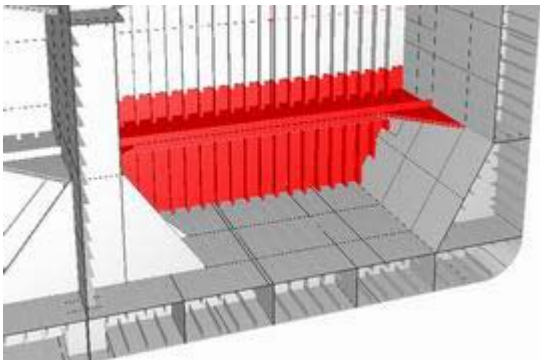
<i>Double Hull Oil Tankers, Ore/oil Ships etc. Measurements i.w.o. close-up - Renewal survey No.1 (Age ~ 5 years)</i>	
 <p>1. One web frame, in a complete ballast tank. See Note 1.</p>	 <p>2. One deck transverse in a cargo oil tank. 2)</p>
 <p>3. One transverse bulkhead (4) in a complete ballast tank (if e.g. side tank and double bottom tanks are separate tanks, they should both be checked). See Note 1.</p>	 <p>5. Lower part of one transverse bulkhead (5) in a cargo centre tank, if applicable. 4. Lower part of one transverse bulkhead (5) in a cargo wing tank. See Note 2.</p>

- Requirements in 6.6 also apply.
- For details on measurement points, see ch.7.

Footnotes from the Rules :

(1) Web frame in a ballast tank means vertical web in side tank, hopper web in hopper tank, floor in double bottom tank and deck transverse in double deck tank (where fitted), including adjacent structural members. In fore and aft peak tanks web frame means a complete transverse web frame ring including adjacent structural members.

(2) Deck transverse, including adjacent deck structural members (or external structure on deck in way of the tank, where applicable)

(4) Transverse bulkhead complete in ballast tanks, including girder system and adjacent structural members, such as longitudinal bulkheads, girders in double bottom tanks, inner bottom plating, hopper side, connecting brackets.

(5) Transverse bulkhead lower part in cargo tank, including girder system, adjacent structural members (such as longitudinal bulkheads) and internal structure of lower stool, where fitted.

Note 1: Complete ballast tank: means double bottom tank plus double side tank plus double deck tank, as applicable, even if these tanks are separate.

Note 2: Where no centre cargo tanks are fitted (as in the case of centre longitudinal bulkhead), transverse bulkheads in wing tanks shall be surveyed.

(IACS UR Z10.4)

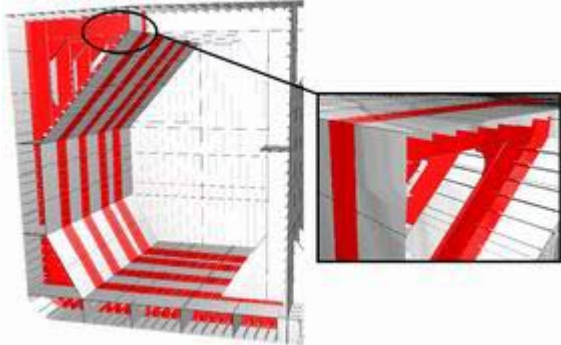
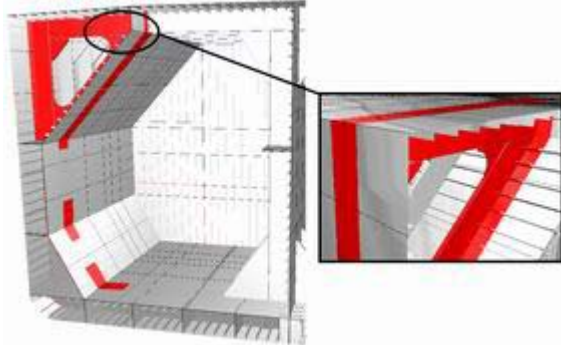
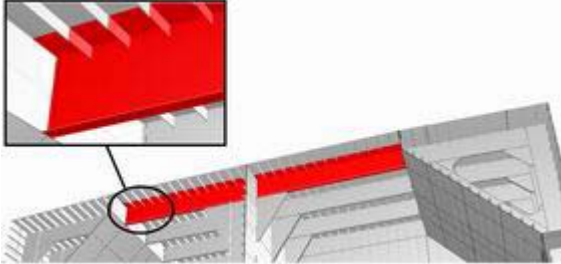
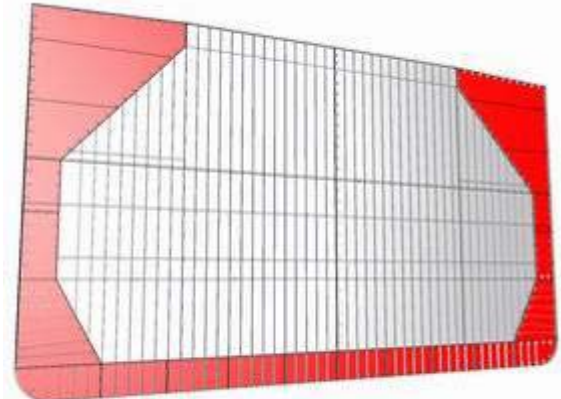
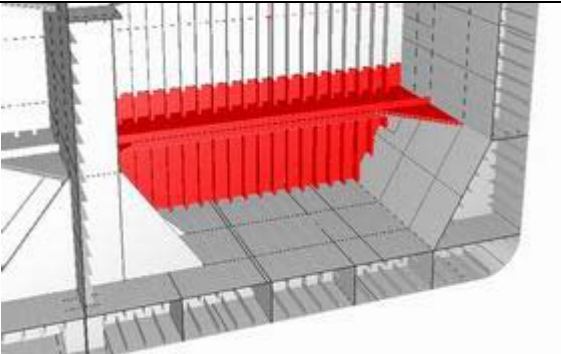
<i>Double Hull Oil Tankers, Ore/oil Ships etc. Measurements i.w.o. close-up - Renewal survey No.2 (Age ~ 10 years)</i>	
	
<p>1. a) All web frames (1), in a complete ballast tank. See Note 1.</p>	<p>1.b) The knuckle area and the upper part (5 metres approximately) of one web frame in each remaining ballast tank (from ballast tank side only).</p>
	
<p>2. One deck transverse in two cargo oil tanks (2).</p>	<p>3. One transverse bulkhead (4), in each complete ballast tank. See Note 1.</p>
	
<p>4. Lower part of one transverse bulkhead (5) - in two cargo oil centre tanks, if applicable. Lower part of one transverse bulkhead (5)- in a cargo oil wing tank (See Note 2).</p>	

- Requirements in 6.6 also apply.

- For details on measurement points, see ch.7.

Footnotes from the Rules :

(1) Web frame in a ballast tank means vertical web in side tank, hopper web in hopper tank, floor in double bottom tank and deck transverse in double deck tank (where fitted), including adjacent structural members. In fore and aft peak tanks web frame means a complete transverse web frame ring including adjacent structural members.

(2) Deck transverse, including adjacent deck structural members (or external structure on deck in way of the tank, where applicable)

(4) Transverse bulkhead complete in ballast tanks, including girder system and adjacent structural members, such as longitudinal bulkheads, girders in double bottom tanks, inner bottom plating, hopper side, connecting brackets.

(5) Transverse bulkhead lower part in cargo tank, including girder system, adjacent structural members (such as longitudinal bulkheads) and internal structure of lower stool, where fitted.

(6) The knuckle area and the upper part (5 metres approximately), including adjacent structural members. Knuckle area is the area of the web frame around the connections of the slope hopper plating to the inner hull bulkhead and the inner bottom plating, up to 2 metres from the corners both on the bulkhead and the double bottom.

Note 1: Complete ballast tank: means double bottom tank plus double side tank plus double deck tank, as applicable, even if these tanks are separate.

Note 2: Where no centre cargo tanks are fitted (as in the case of centre longitudinal bulkhead), transverse bulkheads in wing tanks shall be surveyed.

(IACS UR Z10.4)

*Double Hull Oil Tankers, Ore/oil Ships etc. Measurements i.w.o. close-up
- Renewal survey No.3 and subsequent (Age ~ 15 years and above)*

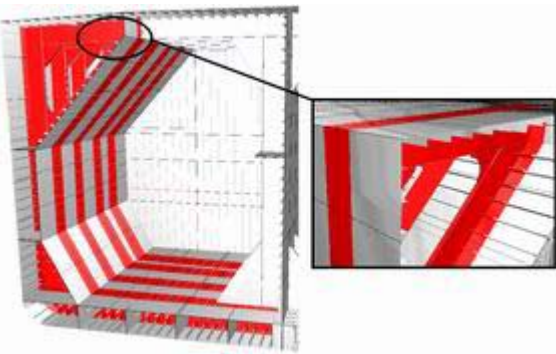
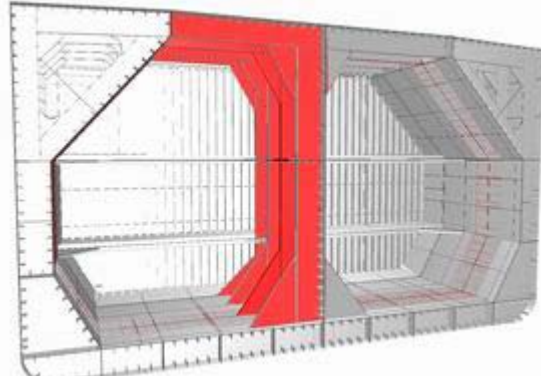
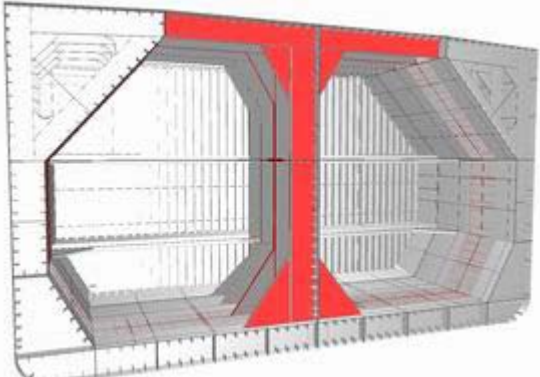
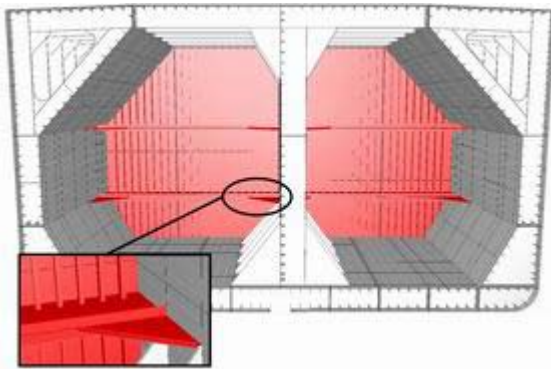
 <p>1. All web frames (1), in all ballast tanks.</p>	 <p>2.a) All web frames (7), including deck transverses and cross ties if fitted, in a cargo oil tank.</p>
 <p>2.b) One web frame (7), including deck transverses and cross ties if fitted, in each remaining cargo oil tank.</p>	 <p>4.a) All transverse bulkheads - in all cargo oil (3) tanks.</p>

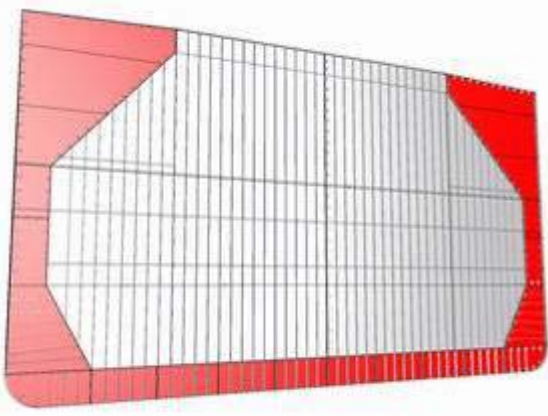
	<p>Renewal survey no.4 and subsequent should have additional transverse areas as deemed necessary by the surveyor.</p>
---	--

4.b) All transverse bulkheads in all ballast tanks (4).

- Requirements in 6.6 also apply.
- For details on measurement points, see ch.7.

Footnotes from the Rules :

(1) Web frame in a ballast tank means vertical web in side tank, hopper web in hopper tank, floor in double bottom tank and deck transverse in double deck tank (where fitted), including adjacent structural members. In fore and aft peak tanks web frame means a complete transverse web frame ring including adjacent structural members.

(3) Transverse bulkhead complete in cargo tanks, including girder system, adjacent structural members (such as longitudinal bulkheads) and internal structure of lower and upper stools, where fitted.

(4) Transverse bulkhead complete in ballast tanks, including girder system and adjacent structural members, such as longitudinal bulkheads, girders in double bottom tanks, inner bottom plating, hopper side, connecting brackets.

(7) Web frame in a cargo oil tank means deck transverse, longitudinal bulkhead vertical girder and cross ties, where fitted, including adjacent structural members.

Note 1: Complete ballast tank: means double bottom tank plus double side tank plus double deck tank, as applicable, even if these tanks are separate.

Note 2: Where no centre cargo tanks are fitted (as in the case of centre longitudinal bulkhead), transverse bulkheads in wing tanks shall be surveyed.

(IACS UR Z10.4)

6.9 Chemical tankers ESP - Measurements i.w.o. close-up inspections

(DNV Rules Pt.7 Ch.2 Table K1)

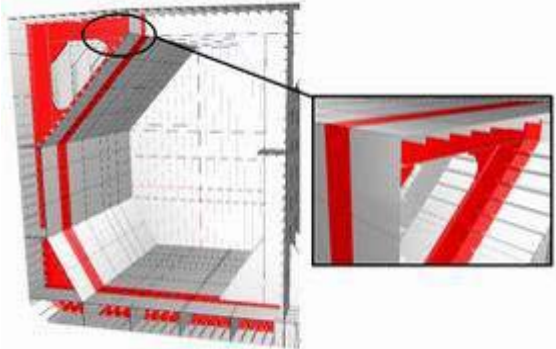
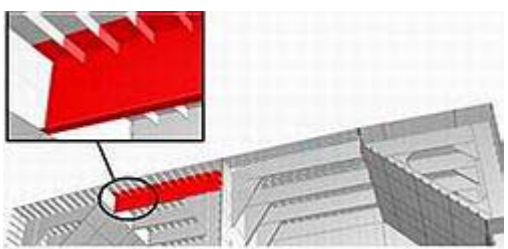
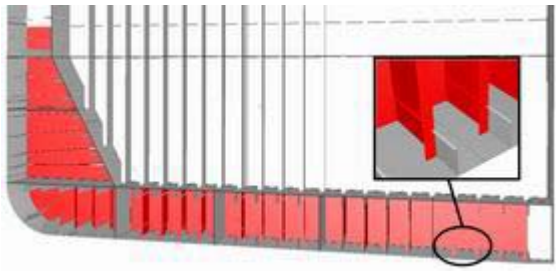
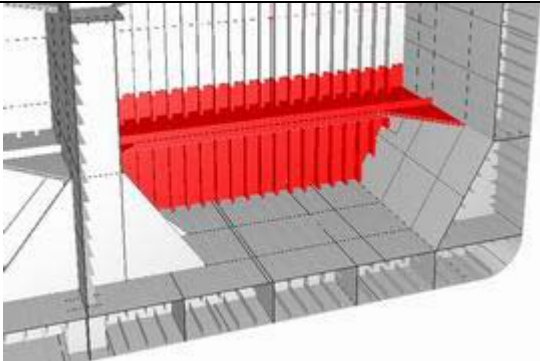
<i>Chemical tankers, measurements i.w.o. close-up - Renewal survey No.1 (Age ~ 5 years)</i>	
 <p>1. One transverse section - in a ballast wing tank or double hull tank.</p>	 <p>2. One deck transverse in a cargo tank or on deck.</p>
 <p>3. Lower part of one transverse bulkhead in a ballast tank.</p>	 <p>4. Lower part of one transverse bulkhead in a cargo wing tank. 5. Lower part of one transverse bulkhead in a cargo centre tank.</p>

- Requirements in 6.6 also apply.
- For details on measurement points, see ch.7.
- Close-up examination of a transverse section cover longitudinal, vertical and transverse structure.
- Double hull tank includes double bottom and side tank even though these tanks are separated

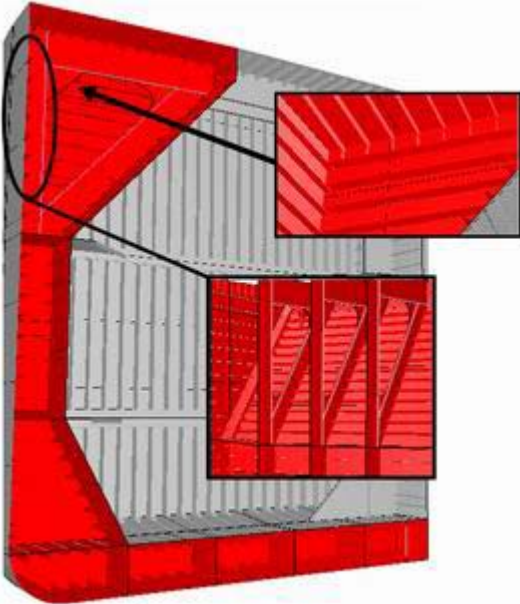
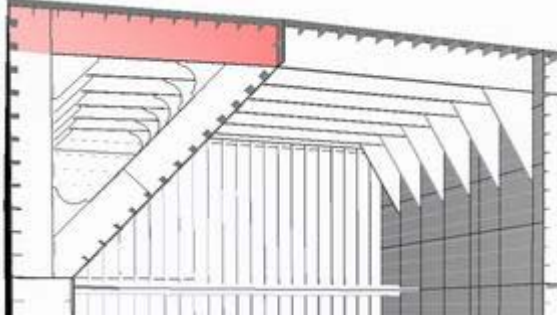
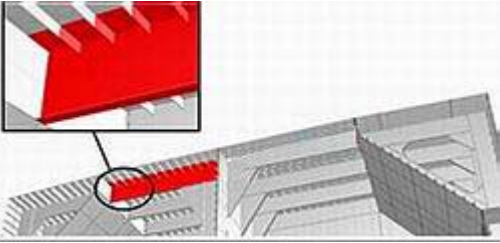
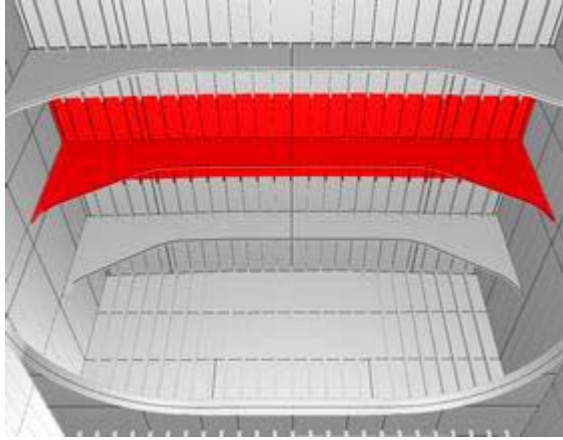
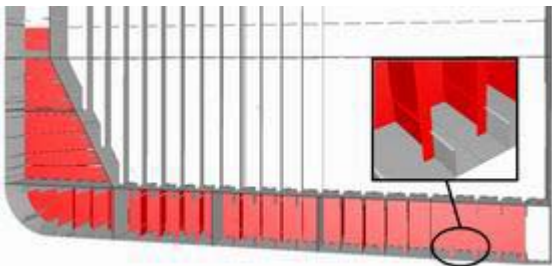
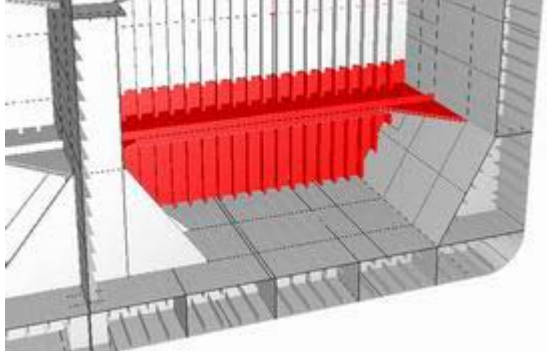
<i>Chemical tankers, measurements i.w.o. close-up - Renewal survey No.2 (Age ~ 10 years)</i>	
 <p>1. All plating and internal structure in a ballast wing tank or double hull tank.</p>	 <p>2. One deck transverse - in each remaining ballast tank or on deck.</p>
 <p>3. One deck transverse in a cargo wing tank or on deck.</p>	 <p>4. One deck transverse, in two cargo centre tanks or on deck, if there are centre tanks.</p>
 <p>5. Lower part of one transverse bulkhead - in each remaining ballast tank.</p>	 <p>6. Lower part of one transverse bulkhead - in a cargo wing tank. 7. Lower part of one transverse bulkhead - in two cargo centre tanks, if applicable.</p>

- 1) Requirements in 6.6 also apply.
- 2) For details on measurement points, see ch.7.
- 3) Close-up examination of a transverse section cover longitudinal, vertical and transverse structure.
- 4) Double hull tank includes double bottom and side tank even though these tanks are separated

*Chemical tankers, measurements i.w.o. close-up
- Renewal survey No.3 and subsequent (Age ~ 15 years and above)*

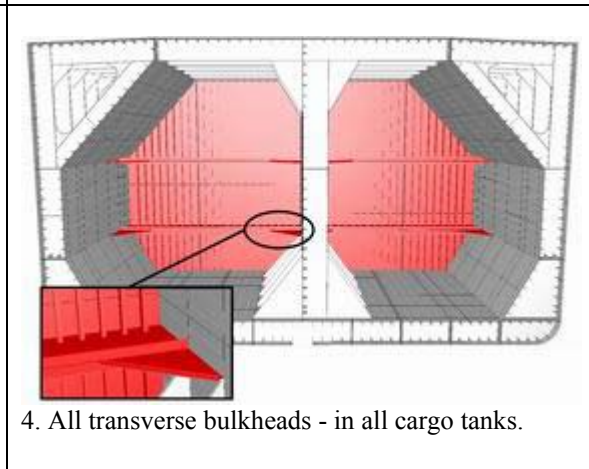
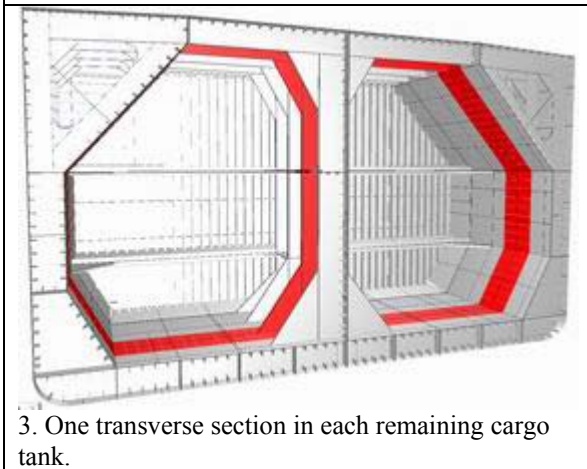
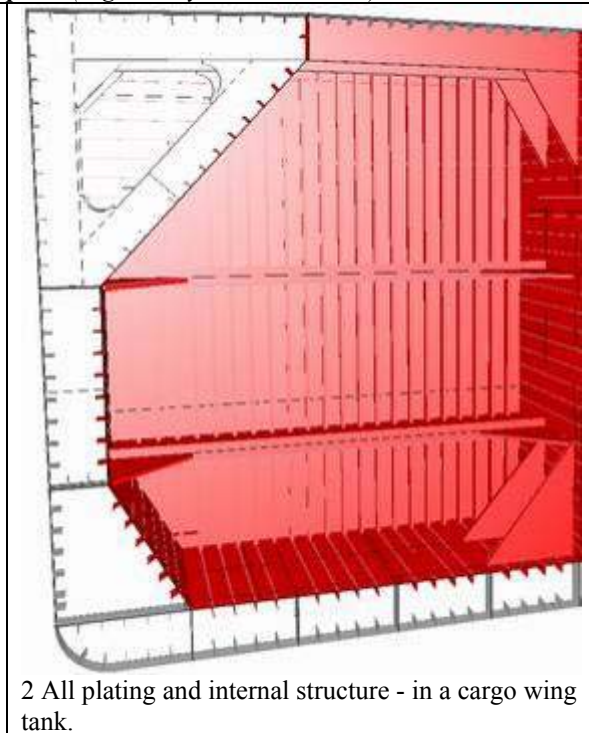
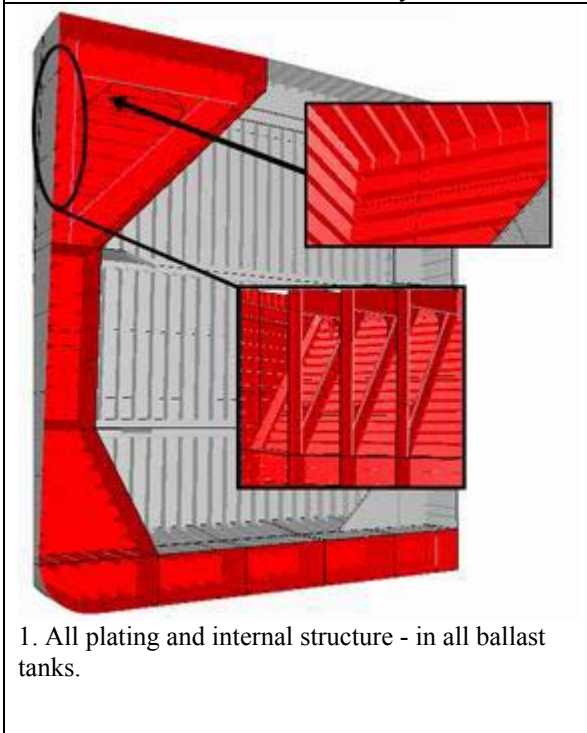

- 1) Requirements in 6.6 also apply.
- 2) For details on measurement points, see ch.7.
- 3) Close-up examination of a transverse section cover longitudinal, vertical and transverse structure.
- 4) Double hull tank includes double bottom and side tank even though these tanks are separated

7. Thickness measurement pattern

7.1 Number of measurement points per plate and averaging

Measurements shall be taken at the forward, middle and aft area of all plates, minimum 3 measurements per plate. This applies for e.g. deck, bottom and wind- and water strakes. **NB ! Requirements at CAP surveys may be stricter, e.g. one measurement in the middle of each plate and one in each corner, five in all.** Where plates cross ballast/cargo tank boundaries, separate measurements for the area of plating in way of each type of tank shall be recorded. Where patches of steel plates have been renewed earlier; be careful to check both the new and the old steel plates. There has been incidents where measurements were taken solely of the newest steel plates, and original plating close by was not measured, even though it was heavily corroded.

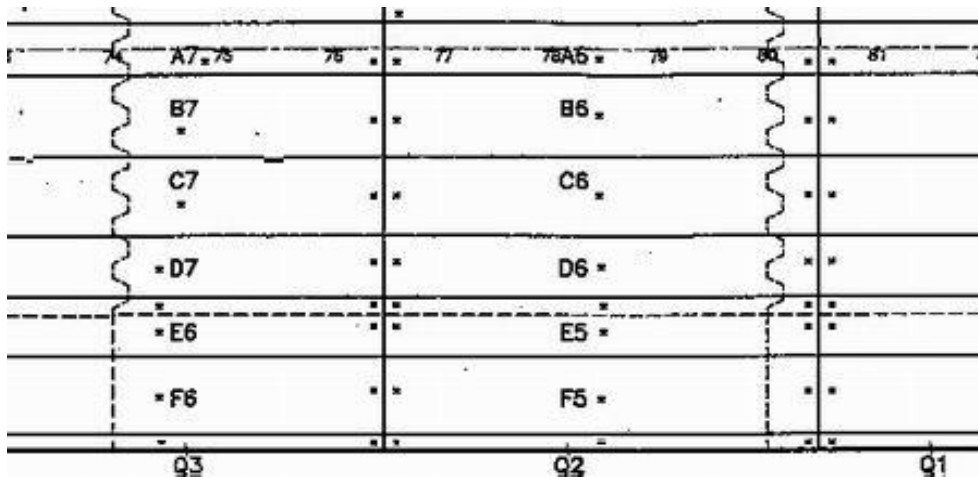

Fig.7.1.1 Measurement points in main deck, marked as black dots. Full line is plate boundaries. Dotted line is bulkheads underneath.

Readings to be included in the UTM report shall be representative for the area measured, and shall normally be single point readings. If a single reading is not considered to be representative for an area, additional readings shall be carried out, with a comment in the report stating that these are additional readings. Alternatively, the average value of several readings in a small area may be included in the report together with a comment stating that this is an average value. In such cases all the readings to be averaged are to be taken within the affected area. The size of such a "small area", shall typically be the spacing of the stiffeners (longitudinals in tankers or side frames in bulk carriers), with the same length used both in the ship's transverse and longitudinal direction (Fig. 7.1.2). The average thickness of that area shall then be entered in the report, and used to compare with minimum thickness and substantial thickness values, even if single readings within that area are less.

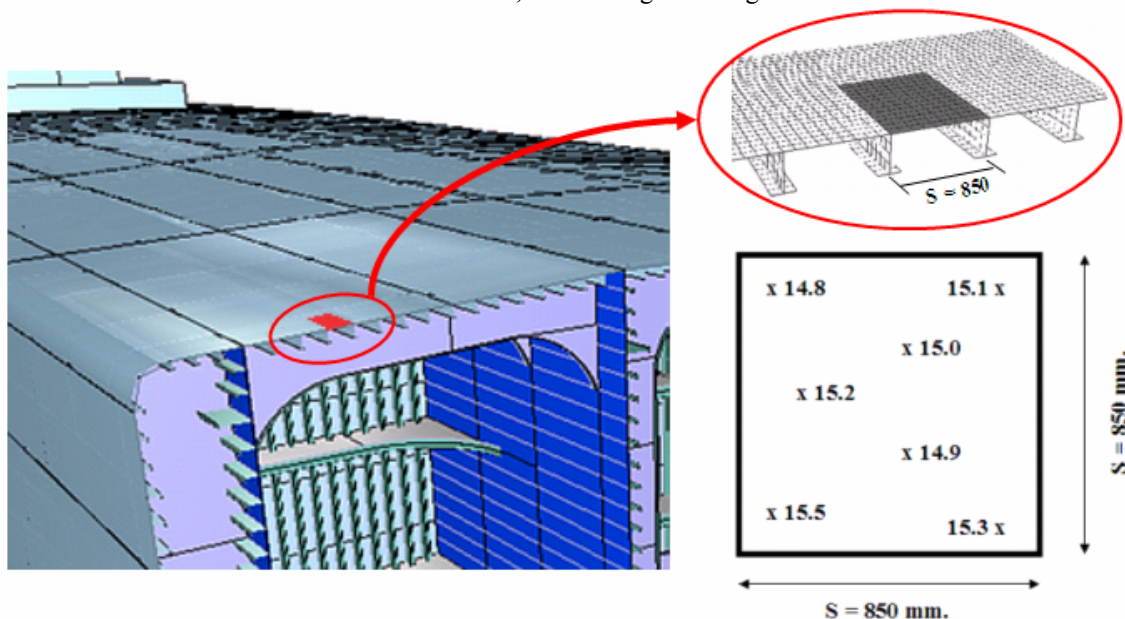

Fig.7.1.2

The only reading noted in the report would be $(14.8+15.1+15.0+15.2+14.9+15.5+15.3)/7=15.1$

The number of measurement points in the figure were just an example. How many points needs to be taken, in order to get a representative average, will depend on the thickness variations within that space.



Fig.7.1.3 Pitting corrosion

If there is pitting corrosion, this should be mapped separately, indicating minimum thickness measured, size of area affected, percentage of area covered by pits and average pitting depth. The surveyor shall be informed. The surveyor will use separate acceptance criteria to decide if the area in question needs to be renewed. Common location for pitting corrosion is the bottom plating underneath pipe suction bellmouths in ballast- and cargo tanks, and at the aft end of crude oil tanks.

The thickness of stiffeners may be "averaged" in the same manner as for plates, with the web height or the flange width, as applicable, being the length of each side in a quadratic area. A mean thickness is calculated for that area, as under Fig.7.1.2.

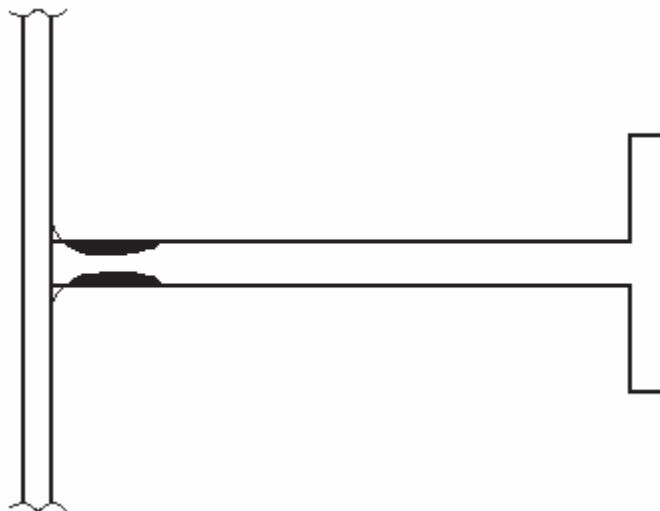

Fig.7.1.4 Grooving corrosion

If there is grooving corrosion at the base of a stiffener, the affected area should be mapped, with absolute minimum thickness, average thickness of affected area and length of grooving noted down. The surveyor shall be informed. The surveyor will use separate acceptance criteria for grooving corrosion.

7.2 Transverse sections

The transverse sections measured should generally be within 0.5L amidship and where the largest thickness reduction is expected to occur or is revealed from deck and bottom plating measurements.

The results are used for longitudinal strength evaluation and significant area reduction in deck or bottom i.e. above 5%, may require measurements of additional transverse sections. Further, if significant reduction is revealed in some areas, e.g. in the deck longitudinals, measurements may be extended to ensure satisfactory condition for deck longitudinal in other areas of the tank.

Minimum density of readings at each transverse section

- Within 0.15D from deck and bottom every longitudinal and girder shall be measured on the web and flange and every plate shall be measured one point between each longitudinal.
- Between deck and bottom area every longitudinal and girder shall be measured on the web and flange and every plate strake at least one point pr strake.

See illustrations in Fig. 7.5.1 for General Cargo, Fig. 7.5.6 for Tankers and Fig. 7.5.8 for Bulk Carriers.

7.3 Bulkheads and web frames

See Fig. 7.5.4, 7.5.5 and 7.5.10 for the bulkheads and Fig. 7.5.7, 7.5.8 and 7.5.9 for the web frames. The figures apply whether the measurements are part of the systematic requirements or as part of the close-up inspection. At least one row of measurements should be taken in the upper part, in the lower part, and in addition one row between each of the stringers. As figure 7.5.4 indicates, where there is a plate joint with different thickness in each of the abutting plates, measurements should be taken of each of the two abutting plates. For bulkheads or web frames not corresponding completely with any of the following figures, use the figures as guidance to work out a pattern for that particular design.

7.4 Measurements i.w.o. close-up inspections

The rules specify minimum requirements to thickness measurements for assessment of general corrosion and required extent of measurements will be as found necessary by attending DNV Surveyor, to evaluate all corroded structure. Readings from initial measurements showing that more than 50% of corrosion margin is used, will normally require extended scope to confirm satisfactory condition for similar elements in the rest of the tanks. Proposed initial scope of measurements are indicated in the following figures, but final scope of measurements will to a large extent be decided on board.

7.5 Figures with location of measurement points

All Ships - Transverse Section

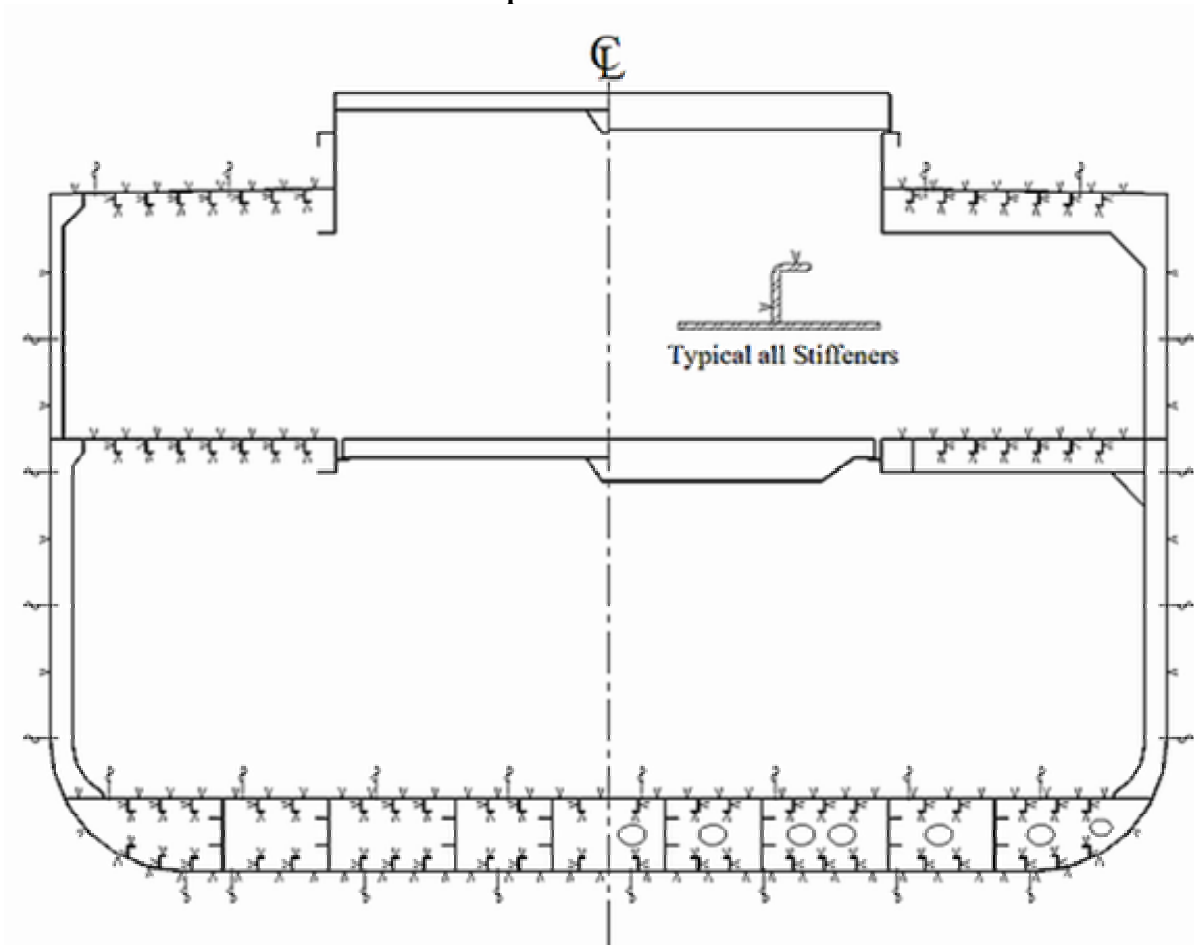

Fig. 7.5.1

Transversely stiffened ships (such as bulk carriers and general cargo ships), shall also have random measurements taken of the adjacent, transverse frames forward and aft of the transverse section.

All ships (incl. bulk carriers) hatch cover

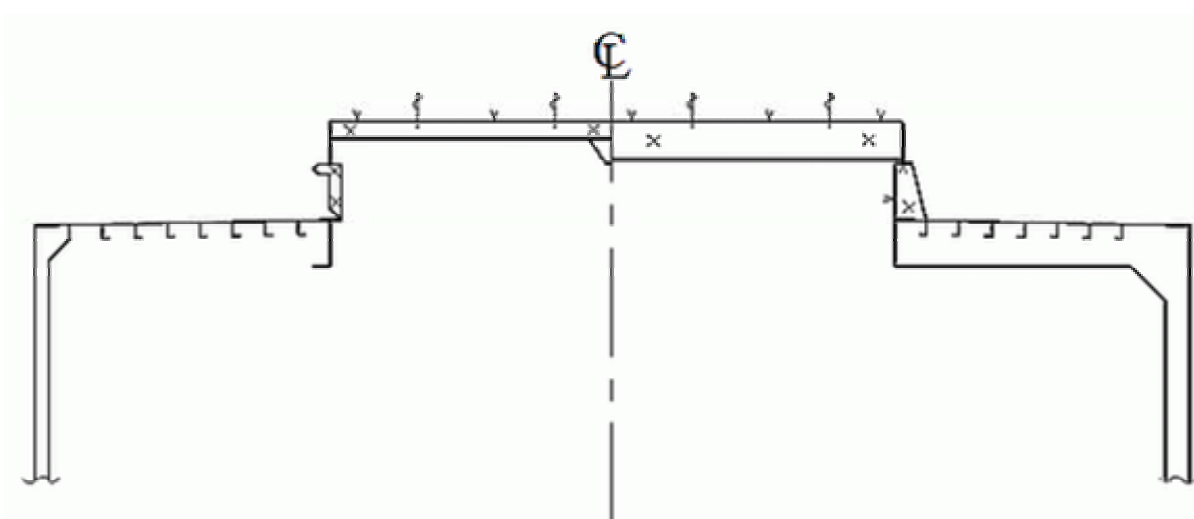
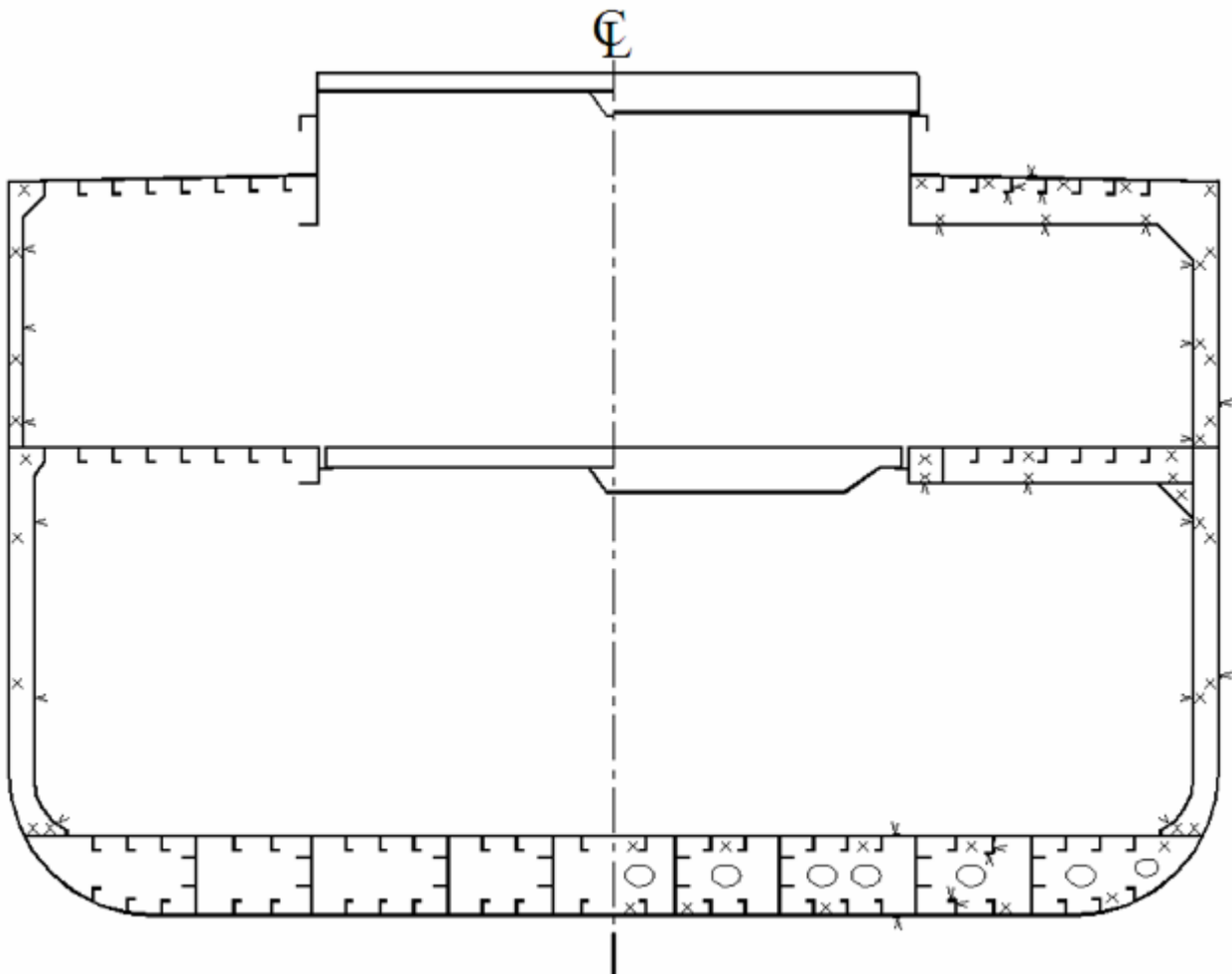

Fig.7.5.2

All ships - web frames, deck transverses, internals, floors.

Fig.7.5.3



Where the original web plating has strakes with different thickness, measurements should be taken from each of the different strakes. Spot checks should be taken of plating/stiffeners in adjacent structure. At least one of each i.w.o. each boundary in each space (e.g. one measurement of plating, and one web and flange of a longitudinal, in the deck and upper side in the upper cargo hold).

**All ships - Transverse and longitudinal bulkheads with vertical stiffeners
(Also applies to bulk carriers and tankers)**

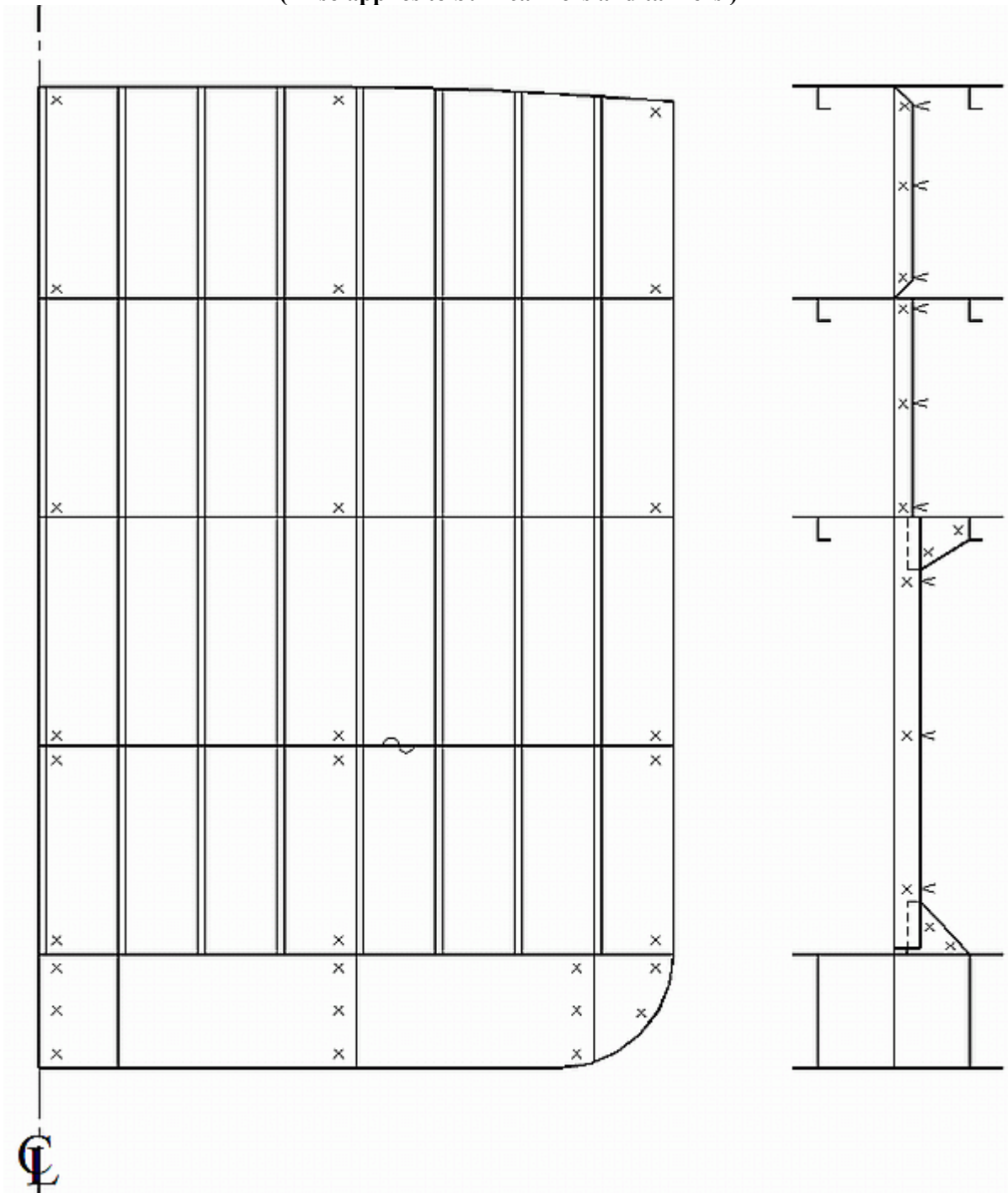

Fig.7.5.4

All Ships - Stringers on Transverse Bulkheads
 (From Tanker Structure Co-Operative Forum. See 5)

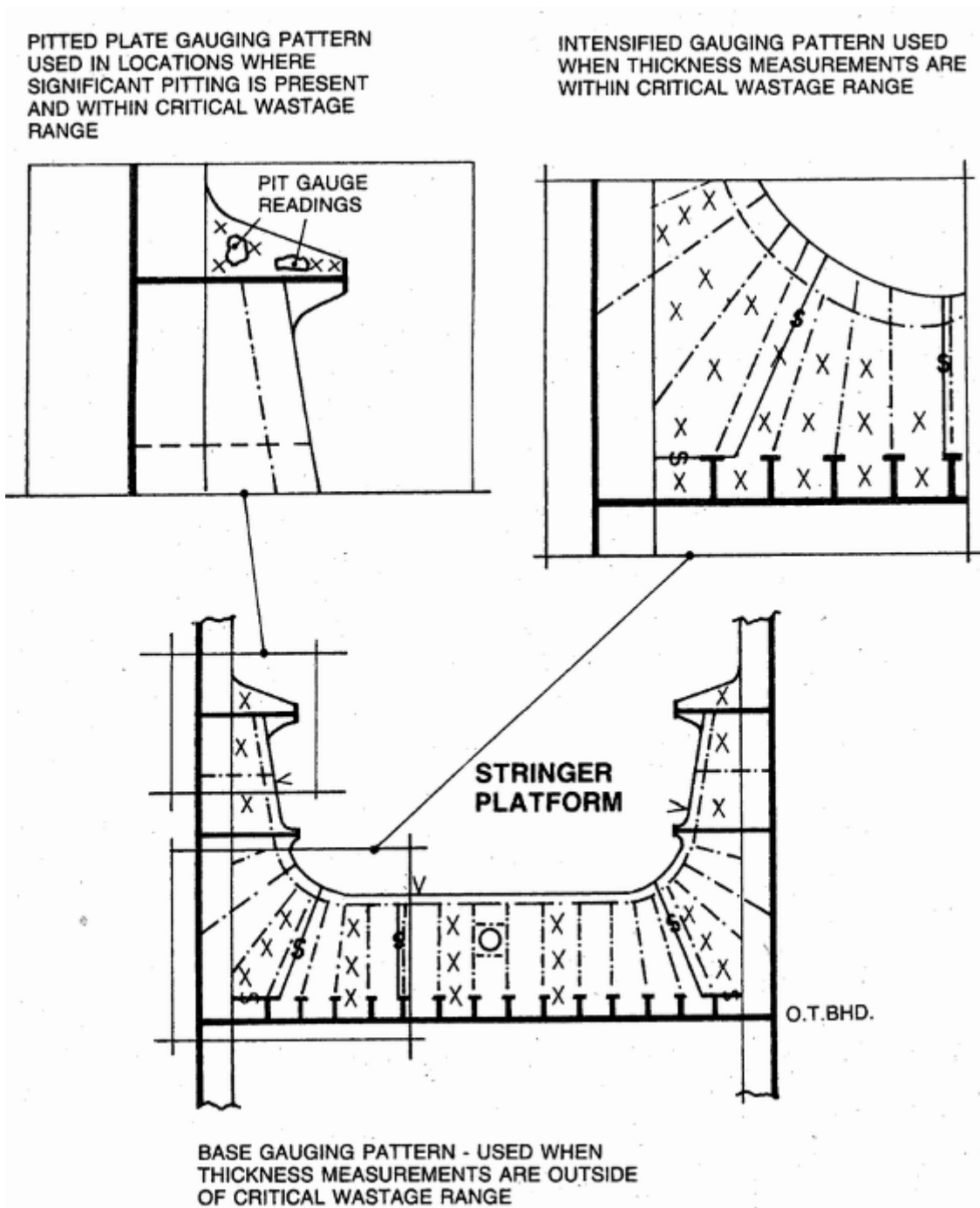

Fig.7.5.5

Oil Tankers - Transverse section

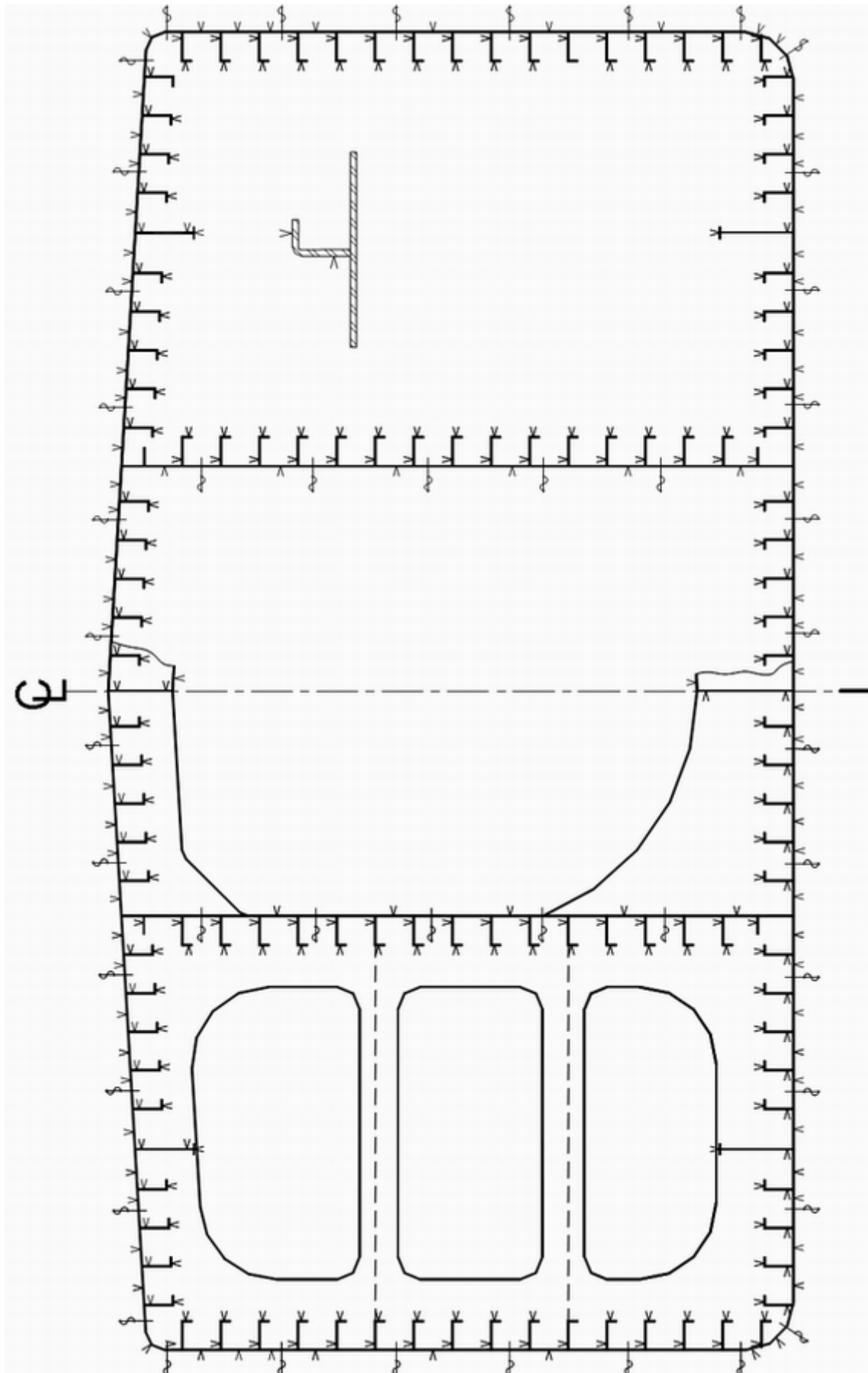

Fig.7.5.6

Oil Tankers web frame

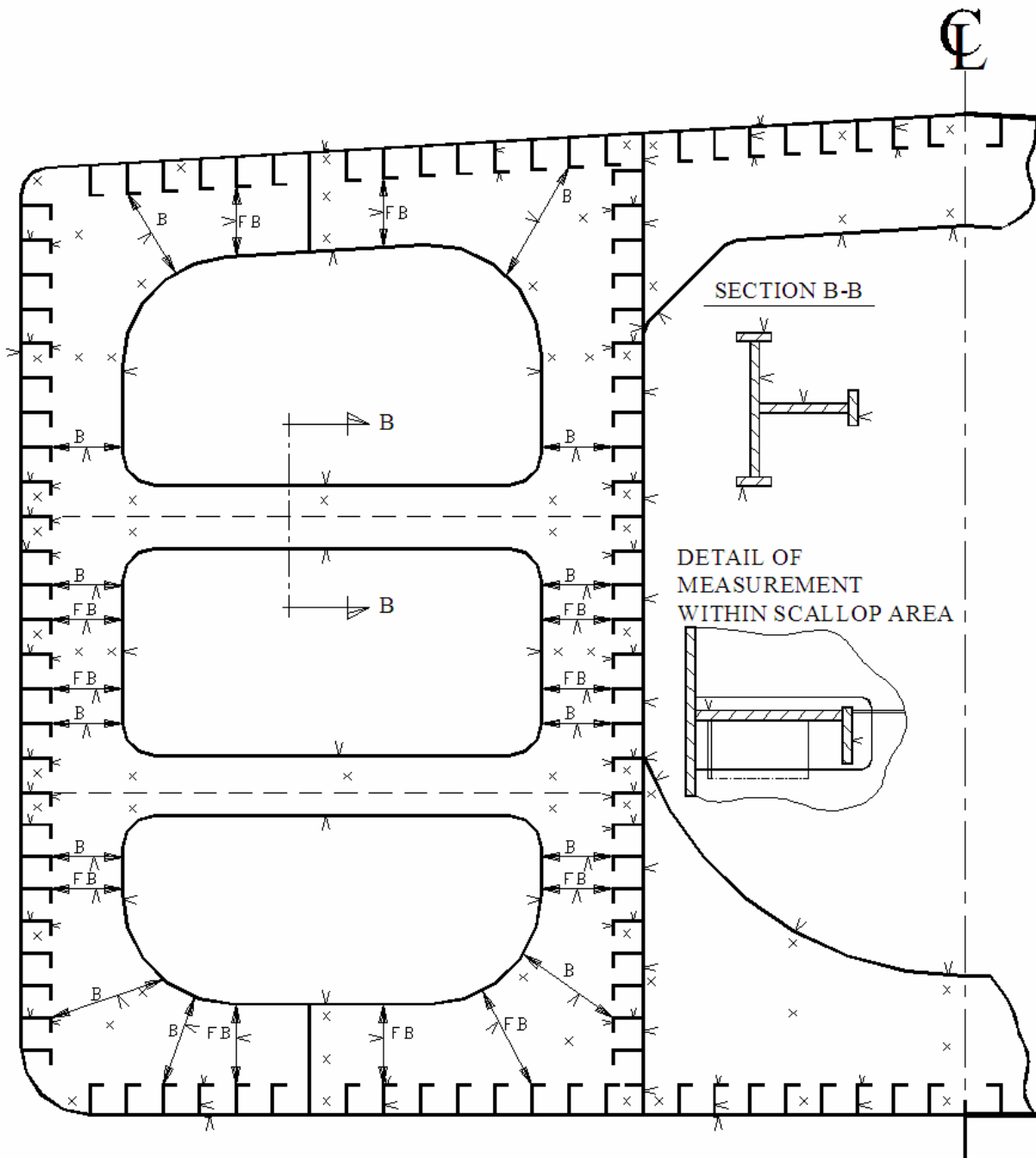

Fig.7.5.7

Where the original web plating has strakes with different thickness, measurements should be taken from each of the different strakes. Spot checks should be taken of plating/stiffeners in adjacent structure. At least one representative reading of plating/stiffener i.w.o. each boundary in each tank (e.g. one measurement of plating, and one web and flange of a longitudinal, in the deck, side and bottom in the wing tank).

Bulk Carriers - Transverse Section

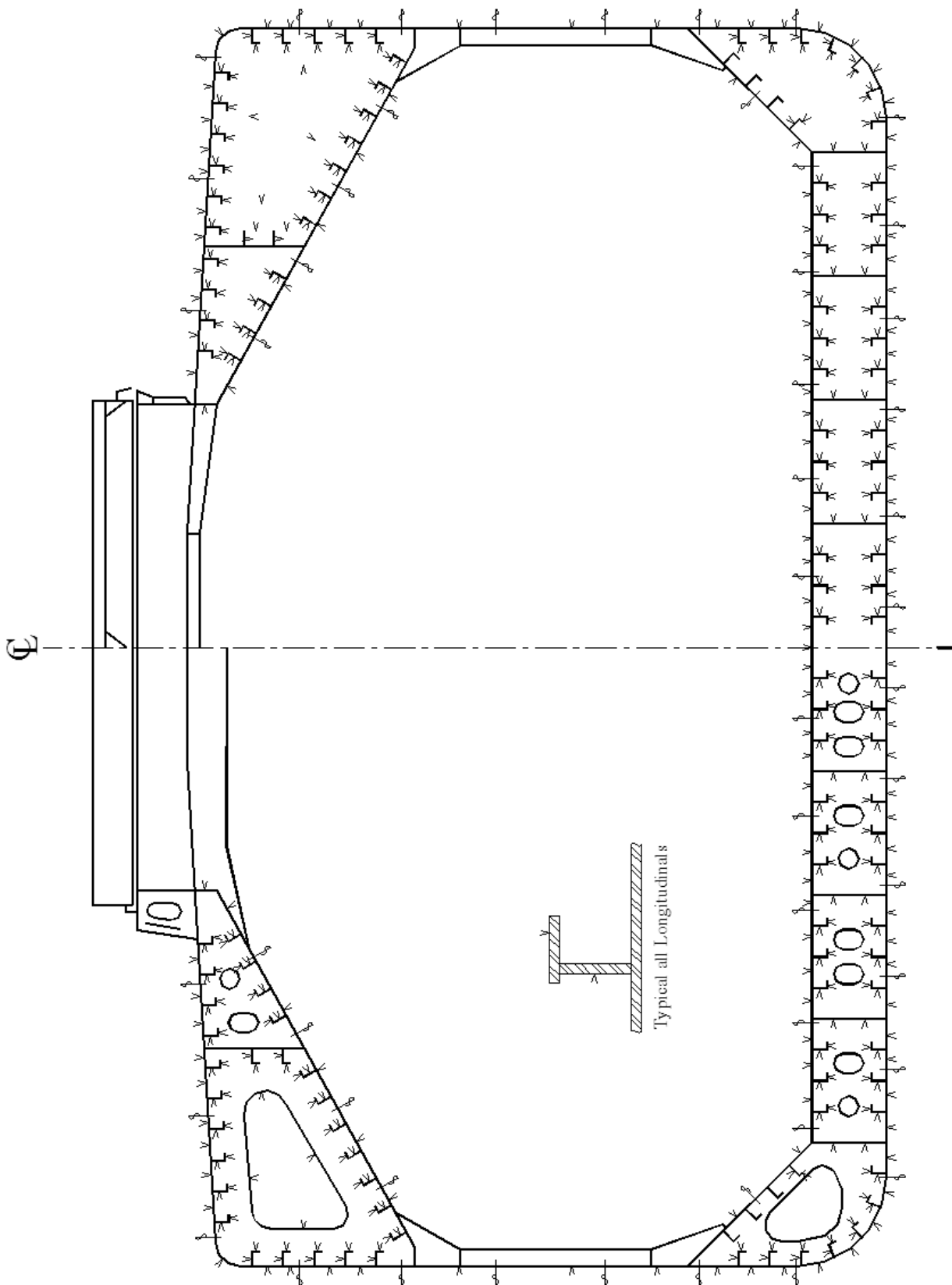

Fig.7.5.8 - Transversely stiffened ships (such as bulk carriers and general cargo ships), shall also have random measurements taken of the adjacent, transverse frames forward and aft of the transverse section.

Bulk Carriers - Web Frame

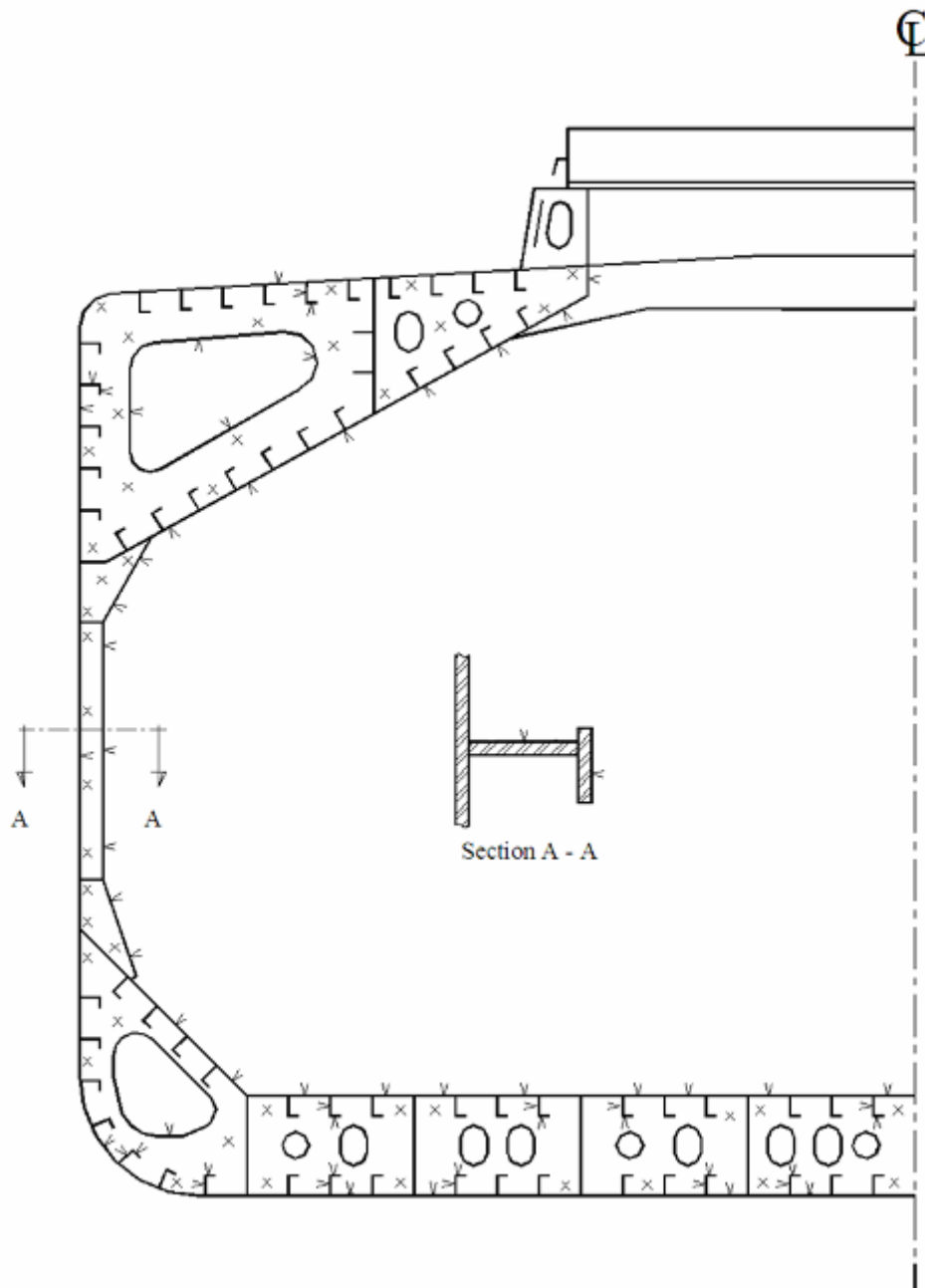

Fig.7.5.9

Where the original web plating has strakes with different thickness, measurements should be taken from each of the different strakes. Spot checks should be taken of plating/stiffeners in adjacent structure. At least one reading of plate/stiffener i.w.o. each boundary in each tank (e.g. one measurement of plating, and one web and flange of a longitudinal, in the deck, upper side and the slanted part in the bottom of a topside tank).

Bulk Carriers - Transverse, Corrugated Bulkhead

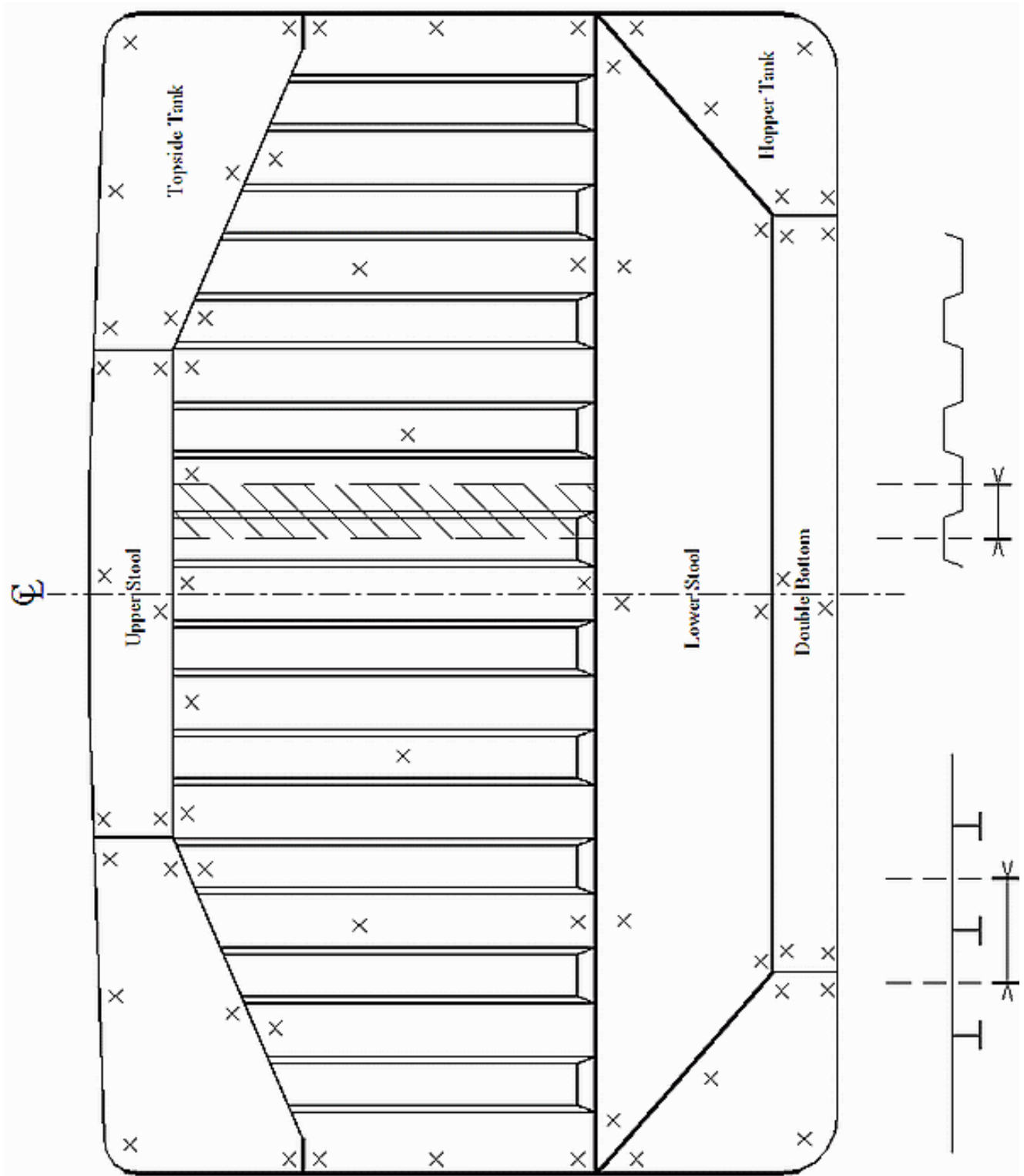

Fig.7.5.10

7.6 Mapping of areas with substantial corrosion

Areas found with Substantial Corrosion should be mapped applying gauging patterns in the rules. Detailed requirements are given in Appendix D.

Appendix A Kick-off meeting – Agenda and Minutes of Meeting

SURVEY MEETING # (With reference to requirements of IACS PR19)			
NAME OF VESSEL		DATE	
DNV ID No		LOCATION	

Scope:

A meeting was held in order to discuss the requirements for safe and efficient execution of surveys and thickness measurements to be carried out in conjunction with the COMMENCEMENT / COMPLETION* of ANNUAL / INTERMEDIATE / RENEWAL /* survey, on the date(s) noted above.

Attended by:

Function	Company Name	Personnel
Owner's Representative		1. 2. 3. 4.
Approved Thickness Measurement Company**		1. 2. 3.
Surveyors	Det Norske Veritas AS	1. 2. 3.

Minutes of meeting

The following general topics were discussed with details (comments) as follows:

<p>• Personal Safety : (Means of access, gas freeing, safety equipment such as gas- and oxygen meters, means of communication, point of contact in the case of an accident, ballast pumping procedures etc.)</p> <p>Comments :</p>
<p>• Schedule for thickness measurement.</p> <p>Comments:</p>
<p>• Provisions for thickness measurements (cleaning, illumination, ventilation)</p> <p>Comments:</p>
<p>• Scope of the survey:</p> <ol style="list-style-type: none"> 1) Mandatory extent of thickness measurements. Ref. Pt.7 Ch.2 Sec.2 Table D3 (applies to all ships) or Table I2 (Requirements for general cargo ships), or Sec.3 Table F2 (bulk carriers ESP), Table G3 (oil tankers ESP, single hull), Table G4 (oil tankers ESP, double hull) or Table K2 (tankers for chemicals ESP). Chapter 6 and 7 of this guideline contains illustrations of the above requirements. 2) Areas subject to close-up surveys and thickness measurements, including areas previously identified with substantial corrosion, as applicable. Ref. chapter 6 and 7. 3) Taking representative readings, of areas in general, and where uneven corrosion or pitting is found. Ref. first part of chapter 7. 4) Procedure for additional readings and/or mapping of new areas with substantial corrosion. Ref. chapter 4.5 and Appendix D. <p>Comments:</p>

• Availability onboard of drawings with original scantlings.				
Comments:				
• Allowable thickness diminution (Minimum thickness list to be provided by surveyor. UTM company shall enter the min. thickness values into the UTM report template prior to commencement of measurements).				
Comments:				
• Communication.				
<ul style="list-style-type: none"> - Measurements which shall be done during close-up inspection by surveyor. - Reporting of thickness measurements on a regular basis (shall be agreed. E.g. end of the day. Ref. ch. 4.5). - Prompt notification to the surveyor in case of findings like: <ul style="list-style-type: none"> - Excessive and/or extensive corrosion or pitting / grooving of any significance. - Structural defects like buckling, fractures and deformed structures. - Detached and / or holed structure. - Corrosion of welds. - Doubler plates e.g. inside cargo tanks (Ref. chapter 4.5) 				
Comments:				
• Review of Thickness Measurement Firm's documents.				
<ul style="list-style-type: none"> - Equipment to be used (enter below). - Personnel records of operators scheduled for thickness measurement onboard. 				
Company Approval valid *	YES		NO	
Equipment Used: (Name)				
Comments:				

SIGNED:	
Owner's Representative (s)	:
Representative (s) of Thickness Measurement Company	:
DNV Surveyor (s)	:

Footnotes

- Survey meetings shall be held each time, if thickness measurements are carried out in several operations during the allowable period for the survey and / or by different thickness measurement firms.

* - Delete as necessary.

** - Only UTM Companies certified by DNV shall be used.

Appendix B - Approval Programme No. 402 April 2004 : Approval of Firms Engaged in Ultrasonic Thickness Measurements of Ship's Structure. NB ! April 2004 version. See ch.5. for applicability.

CONTENTS

1. Application
2. Objective
3. Procedure for Approval and Certification
 - 3.1 Documentation
 - 3.2 Auditing
 - 3.3 Quality Assurance System
 - 3.4 Requirements
 - 3.4.1 Training and Qualifications
 - 3.4.2 Supervision
 - 3.4.3 Personnel records
 - 3.4.4 Equipment and facilities
 - 3.4.5 Work procedures
 - 3.4.6 Execution
 - 3.4.7 Sub-contractors
 - 3.4.8 Verification
 - 3.4.9 Reporting
4. Approval
5. Information of Alterations to the Certified Service Operation System
6. Cancellation of Approval
7. Re-approval
8. Thickness measurements on smaller vessels

On the net: DNV Electronic Report Form

Revised: 2004.01.28

1. Application

Firms carrying out thickness measurements on board all ESP-vessels and other vessels of 500 GT or larger, except fishing vessels, on behalf of the owner of a ship, the results of which is used by DNV Surveyors in making decisions affecting classification, are subject to approval by DNV in accordance with the mandatory procedures in this requirement.

The approval requirements are based on IACS unified requirements, Z17 as amended and partly on EN 45004.

2. Objective

The objective of this programme is to ensure that measurements and reporting of structural scantlings are correct. This is done by ensuring that firms engaged in thickness measurements have qualified personnel that is able to recognise corroded or pitted areas and understand ship's drawings, implemented written systems for training, control, verification and reporting, in addition to the necessary technical equipment and facilities to render professional assistance.

3. Procedure for Approval

3.1 Documentation

The following documents are to be submitted to the Society for review:

- Outline of company, e.g. organisation and management structure, including subsidiaries
- Experience of the company regarding thickness measurements of ship's structure
- List of operators/supervisor, documenting training, experience and qualifications
- Description of equipment used including routines for maintenance and calibration.
- A guide for operators of such equipment.
- Training programmes for operators
- Quality Manual and/or documented procedures covering requirements in 3.3
- Record of customer claims and of corrective actions requested by certification bodies
- Work Procedures

3.2 Auditing

Upon reviewing the submitted documents with satisfactory result, the firm is audited in order to ascertain that it is duly organised and managed in accordance with the submitted documents, and that it is considered capable of conducting ultrasonic thickness measurements of ship structure.

Approval is conditional on a practical demonstration of thickness measurements on board as well as satisfactory reporting being carried out.

Where several servicing stations are owned by a given company, each station is to be assessed and approved separately, according to the same requirements as for the main company.

One-man-firms are not accepted on large vessels.

3.3 Quality Assurance System

The firm shall have a documented system covering at least the following:

- maintenance and calibration of equipment
- training programmes for operators
- supervision and verification to ensure compliance with operational procedures
- recording and reporting of information
- quality management of subsidiaries and agents
- job preparation
- periodic review of work process procedures, complaints and corrective actions, issuance, maintenance and control of documents.

A documented Quality Assurance system complying with the ISO 9001:2000 standard or equivalent and including the above items, would be considered acceptable.

3.4 Requirements

3.4.1 Training and qualification

The firm is responsible for the training and qualification of its personnel. This is to include Rule requirements. The operators carrying out the measurements shall be certified to a recognised national or international NDT standard (i.e. EN 473 level I or ISO 9712 level I or equivalent, like ASNT-SNT-TC-1A). Operators shall have had a minimum of one (1) year tutored on-the-job training. The operator shall have adequate knowledge of ship's structures sufficient to select a representative position for each measurement.

The responsible supervisor shall have had minimum two (2) years experience as an operator. The responsible supervisor shall be qualified according to a recognised national or international industrial NDT standard (e.g. EN 473 level II or ISO 9712 level II or similar).

3.4.2 Supervision

The firm shall have a permanently employed supervisor available to the operators. The supervisor may, however, work as operator.

3.4.3 Personnel records

The firm shall keep records of approved operators and supervisors. The record shall contain information on age, formal education, training and experience.

Operators and supervisors must speak English.

3.4.4 Equipment and facilities.

Instruments using pulsed echo technique, either with oscilloscope or digital instruments using multiple echo, single crystal technique are required. Single echo instruments are not accepted. A record of the equipment used shall be kept. The record shall contain information on maintenance and calibration. A confirmation from the manufacturer that the instruments satisfy the requirement above shall be enclosed in the instrument record.

3.4.5 Work procedures

The firm shall have documented work procedures covering planning of execution and reporting.

- Practise of verification of readings by attending DNV surveyor to be agreed.
The supplier is responsible for using the latest version of the report form that can be found on www.dnv.com.
- The surveyor's presence shall be recorded in the report.

- All data is to be entered into the template before the job is started, as part of the preliminary preparation.
- Operators and supervisor is to carry ID cards with photo.
- An up-dated list of approved operators and supervisor is to be kept at the approving office so that identification can be verified by the attending surveyor. Readings taken by non-listed operators are to be rejected.

3.4.6 Execution

- The operators are to attend the planning meeting that is held before each job is started.
- Each major class job (IS/RCH) is to be carried out by at least two qualified operators working together.
- Thickness measurements of less extent may be carried out by one operator.
- Measurements that are not carried out in co-operation with DNV will not be accepted. The firm is to inform the owner accordingly. When onboard the operator/supervisor shall have his certificate and identification papers readily available.
- The operator shall notify the DNV surveyor of any structural deficiencies or abnormal measurements detected.

3.4.7 Subcontractors are not to be used.

To hire certified operators from another approved service supplier is not considered sub-contracting. This is, however, to be included in the report.

3.4.8 Verification

The firm must have the DNV surveyor's verification of each separate job.

3.4.9 Reporting

Prior to commencing measurements onboard, in addition to the measured values, the original scantlings, the minimum thickness and the substantial corrosion limits are to be stored in the electronic report.

When on board, measured thicknesses are to be continuously recorded in the DNV Electronic Report Form, based on the operator's working notes, photos and sketches and are regularly to be made available for the attending surveyors review and verification..

Upon completion of the measurements onboard the operator is to provide the DNV surveyor with a temporary electronic draft of the results presented in the DNV Electronic Report Form, and supplied with the operator's notes, as found necessary. The location of the measurements is to be illustrated by sketches or drawings.

The preliminary report is to include a longitudinal strength evaluation when required, (IMO Res.A.744(18) Annex12) valid for oil tanker with length above 130 meters and over 10 years of age, that is at the third renewal survey and subsequent renewal surveys..

Final reporting in electronic form and in printed version or in a non-editable electronic form is to be presented the DNV surveyor within two (2) weeks after the job is terminated. The firm must have the surveyor's verification of each separate job, documented in the report by his signature and the text "Verified and Evaluated"

The report shall include a copy of the Certificate of Approval of the firm, containing name of all approved operators and supervisor.

4. Approval

4.1 Upon satisfactory completion of both the audit of the firm and the demonstration test, DNV will issue a Certificate of Approval stating that the firm's service operation system has been found to be satisfactory. The certificate shall clearly state that the type and scope of services and any limitations or restrictions imposed. The certificate shall also contain a list of certified operators and the supervisor. A copy to be sent MTPNO-374 for recording.

The firm will also be included in DNV's records of approved service suppliers, Register no.102 and in IACS' List of Approved Service Suppliers. (<http://exchange.dnv.com>)

4.2 Renewal or endorsement of the certificate is to be made at intervals not exceeding three (3) years by verification through audits that approved conditions are maintained. Intermediate audits may be required by DNV as found necessary. At least 3 months before the period of validity expire, the supplier shall apply to DNV for renewal of the Certificate of Approval.

5. Information of alterations to the Certified Service Operation System

In case any alteration to the certified service operation system of the firm is made, including changes related to UTM operators, such alteration is to be immediately informed to DNV.

Audit is required when deemed necessary by DNV.

6. Cancellation of Approval

Approval may be cancelled in the following cases:

- Where the measurements were improperly carried out or the results were improperly reported.
- Where a Surveyor finds deficiencies in the approved service operation system of the firm and appropriate corrective action is not taken
- Where the firm fails to inform DNV of any alteration as in §5 above
- Where wilful acts or omissions are ascertained
- When new rule requirements make this necessary.

In cases where the approval is cancelled other IACS members will be informed. A list of approved and rejected UTM firms are found on IACS' website: www.iacs.org.uk (See: Other Technical – Service Supplier Approval)

Any queries related to the list of DNV Approved UTM companies may be asked to:

Approval.Service.Supplier@dnv.com

7. Re-approval

A firm whose approval was cancelled, may apply for re-approval provided he has corrected the non-conformities which resulted in cancellation, and DNV is able to confirm he has effectively implemented the corrective action.

A supplier whose approval by another society is cancelled will have its approval by DNV pending until the cancelled approval is restored. The supplier is not to undertake jobs on DNV-classed vessels in this period and is to inform the owner accordingly.

8.0 Limited Approval of Firms locally engaged in ultrasonic thickness measurements of ship's structure.

8.1. Application

Firms carrying out thickness measurements on non-ESP vessels below 500 GT and on fishing vessels, may be qualified according to the requirements in this chapter.

8.2. Objective

The objective of this limited approval programme is to ensure that firms engaged in thickness measurements have qualified personnel that is able to measure thicknesses, recognise corroded or pitted areas and understand ship's drawings in addition to having the necessary technical equipment to render professional assistance.

8.3. Procedure for Approval

8.3.1 The following documents are to be submitted to the Society for review:

- Description of company's management structure and manning
- Name of operators/Supervisor, documenting training, experience and qualifications
- Description of equipment used including routines for maintenance and calibration.
- A guide for operators of such equipment.

8.3.2 Operator

The operators carrying out the measurements shall be certified to a recognised national or international NDT standard (i.e. EN 473 level I or ISO 9712 level I or equivalent, like ASNT-SNT-TC-1A or Nortest). Operators shall have had a minimum of one (1) year on-the-job training. The operator shall have adequate knowledge of ship's structure sufficient to select a representative position for each measurement.

8.3.3 Equipment

Instruments using pulsed echo technique, either with oscilloscope or digital instruments using multiple echo, single crystal technique are required. Single echo instruments are not accepted. A confirmation from the manufacturer that the instrument satisfies the requirement above shall be enclosed in the instrument record.

8.3.4 Work Execution

- The firm is to attend the planning meeting that is held before each job is started.
- Measurements that are not carried out in co-operation with DNV, unless otherwise agreed, will not be accepted. The firm is to inform the owner accordingly.
- The operator shall notify the surveyor of any structural deficiencies detected.

8.4 Reporting

Measured thicknesses are to be continuously recorded and to be made available for the attending surveyors . The operator is to report in a recognised system and may illustrate the result by sketches or on the drawings. In addition to the measured values, the original scantlings, the minimum thickness and the substantial corrosion limits, are to be included in the report.

Final reporting is to be presented the DNV surveyor within one (1) weeks after the job is terminated. The firm must have the surveyor’s verification of each separate job, documented in the report by his signature.
The report shall include a copy of the Certificate of Approval, containing name of all approved operators.

8.5 Certification

Upon satisfactory completion of both the audit of the firm and the demonstration test, DNV will issue a Certificate of Approval stating that the firm’s service operation system has been found satisfactory. Any alteration to the certified service operation system is to be immediately informed to DNV. The certificate shall clearly state that the type and scope of services and any limitations or restrictions imposed. Renewal or endorsement of the certificate is to be made at intervals not exceeding three (3) years by verification that approved conditions are maintained. Audit is required when deemed necessary by DNV.

8.6. Cancellation of Approval

Approval may be cancelled in the following cases:

- Where the measurements were improperly carried out or the results were improperly reported.
- Where a Surveyor finds deficiencies in the approved service operation system of the firm and appropriate corrective action is not taken
- Where the firm fails to inform DNV of any alteration
- Where wilful acts or omissions are ascertained
- When new rule requirements make this necessary.

A firm whose approval has been cancelled, may apply for re-approval provided he has corrected the non-conformities which resulted in cancellation, and if DNV is able to confirm that he has effectively implemented the corrective action, he may be re-approved.

----- §§§ -----

Appendix C - Approval Programme No. 402 May 2001 : Approval Programme for Service Suppliers Engaged in Thickness Measurements on Ships, High Speed and Light Craft and Mobile Offshore Units.

NB ! May 2001 version. See ch.5. for applicability.

1. General

1.1 Scope

Firms providing services on behalf of the owner, such as thickness measurements shall be approved by the Society. The firms shall be approved according to DNV Rules for Classification of Ships, High Speed and Light Craft or Mobile Offshore Units, Pt.1 Ch.1 Sec.3, A401. In the following, such firms are referred to as the supplier.

1.2 Objective

The objective of this approval programme is to ensure that the supplier, has qualified personnel and has implemented written systems for training, control, verification and reporting. In addition, the supplier shall furnish the necessary technical equipment and facilities commensurate with providing a professional service.

1.3 Extent of engagement

The approval programme defines the procedures required in obtaining the Society's approval for carrying out thickness measurements of structural materials of ships, high speed and light craft and mobile offshore units classed by the Society. The criteria cover quality systems, administrative procedures and work procedures. This approval programme is in agreement with requirements stated in IACS, Z17, in force from 10 December 2000.

1.4 Validity

The approval will be valid for three (3) years.
For cancellation of approval, see item 7.

2. Requirements to supplier

A certificate of approval will be awarded and maintained on the basis of compliance with the following:

2.1 Submission of documents

2.1.1 The following documents are to be submitted for review:

- An outline of the supplier's organisation and management structure, including any subsidiaries to be included in the approval
- A list of nominated agents
- Experience of the supplier in the specific service area
- A list of operators, technicians and inspectors documented training and experience within the relevant service area, including qualifications according to recognised national, international or industry standards, as relevant
- Description of equipment used for the particular service for which approval is sought
- A guide for operators of such equipment
- Training programmes for operators, technicians and inspectors
- Check lists and record formats for recording results of the services referred to in item 2.13
- Quality manual and/or documented procedures covering the requirements given in item 2.3
- Evidence of approval/acceptance by other certification bodies, if any
- Information on other activities which may present a conflict of interest
- Record of customer claims and corrective actions requested by the Society and/or other certification bodies.

2.2 Extent of approval

The supplier shall demonstrate, as required in 2.4 to 2.13, that it has the competence and control needed to perform the services.

2.3 Quality assurance system

2.3.1 Quality system

The supplier shall have a documented quality system, covering at least:

- Maintenance and calibration of the equipment
- Training programmes for the supervisors and the operators
- Supervision and verification of operation to ensure compliance with the approved operational procedures
- Quality management of subsidiaries and agents
- Job preparation
- Recording and reporting of information
- Code of conduct for the activity
- Periodic review of work process procedures, complaints, corrective actions, issuance, maintenance and control of documents.

A documented quality assurance system complying with the ISO 9000 standard or equivalent and including the items listed in 2.3.1 will be considered acceptable.

2.4 Training of personnel

The supplier is responsible for the qualification and training of its supervisors and operators to a recognised national, international or industry standard as applicable, (see item 2.5 and 2.6). A plan for training of the personnel to be included stating i.e. the following:

- The reporting system
- The minimum rule requirements for the ships in question
- Ship's structure, the recognition of corrosion damage, buckles and deteriorated coatings, edge thinning, lamination and other relevant items shall be included.

The plan should also include maintenance of qualifications.

2.5 Supervisor

The supplier shall have a supervisor responsible for the correct execution of measurements and for the professional standard of the operators and their equipment, including the professional administration of the working procedures. The supervisor shall be qualified according to a recognised industrial NDT standard. E.g. EN 473 Level II, ISO 9712 Level II or a corresponding standard. The supervisor shall have a minimum of 2 years experience as an operator.

2.6 Operators

The operator carrying out the measurements shall be certified to EN 473 Level I, ISO 9712 Level I or a corresponding standard and have passed the internal training scheme of the supplier. The operator shall also have at least one year's experience as an assistant operator (minimum 10 different assignments).

2.7 Personnel records

The supplier is required to keep records of the approved supervisor/operators. The record shall contain information on age, formal education, training and experience in thickness measurement.

2.8 Equipment

On coated surfaces, instruments using pulsed echo technique (either with oscilloscope or digital instruments using multiple echo, single crystal technique) are required. Single echo instruments may be used on uncoated surfaces. A record of the equipment used for thickness measurement shall be kept. The record shall contain information on maintenance and calibration.

2.9 Procedures and instructions

The supplier is to have documented work procedures that are at least to contain information on survey preparation, selection and identification of test locations, surface preparation, protective coating preservation and calibration checks, report preparation and content.

2.10 Administrative procedures

The supplier shall have an order reference system where each engagement is traceable to the measurement record.

2.11 Verification

The supplier shall verify that the service provided is carried out in accordance with approved procedures. Executed verification should be documented. The supplier shall have the surveyor's verification of each separate job, documented in the report by the surveyor's signature.

2.12 Sub-contractors

The supplier shall give information of agreements and arrangements if any part(s) of the services provided are subcontracted. Particular emphasis shall be given to quality management by the supplier in the following-up of such subcontracts. Subcontractors providing anything other than subcontracted personnel or equipment shall also meet the requirements of section 2.1 to 2.13 in this programme.

2.13 Reporting

The report shall be based on the system of tables and figures given in Guidelines No. 10 or a similar system. In addition to relevant thickness, the supplier is to report other information, relevant to structural evaluation. The following information should be included in the report, when detected, during the execution of measurements. The attending surveyor shall be notified about:

- Structural defects like buckles, cracks and deformed structural elements
- Extreme corrosion or significant pitting, which is to be mapped
- Corrosion of welds and/or Heat Affected Zone (HAZ)
- Damaged coating or surface finish.

The report shall include a copy of the certificate of approval.

3. Limited approval of the supplier providing thickness measurement services in local geographic areas

Limited approval may be awarded to the supplier who is to carry out thickness measurements in local geographic areas, on non Enhanced Survey Programme (ESP) vessels with Lpp < 100 m. Thickness measurements made by the supplier, according to limited approval, are to be carried out with a surveyor from the Society in attendance. The supplier is to demonstrate to the Society that they have the capability to provide a reliable service and are able to comply with the following criteria:

a) Responsible person

The supplier shall have named person(s) who will have responsibility for the activity in question.

b) Procedures

The supplier shall have documented work procedures according to item 2.10.

c) Equipment

The supplier shall describe the types of measuring instruments to be used, types of materials to be measured and the range of thickness and measuring accuracy. Instruments shall be calibrated in accordance with the manufacturer recommendations. Both oscilloscopes and digital instruments may be used. See item 2.9.

d) Operator

The ultrasonic equipment operators shall be qualified according to EN 473 Level I, ISO 9712 Level I, as a minimum, or to other recognised certification scheme accepted by the Society.

e) Reports

The reporting format (see DNV Guidelines No. 10) used by the supplier shall, as a minimum, identify: dates, original thickness, thickness measured, location of measurements, per cent reduction, equipment used, reference to procedure and name of operator and supplier. The surveyor's verification is to be documented in the report.

f) Certificate of approval Certificate of approval, see item. 5.1. Limitation according to ESP and vessels with Lpp < 100m will be stated in the certificate.

4. Approval procedures

4.1 Initial audit

The surveyor from the Society will carry out an audit of the supplier once all documentation and information received from the supplier has been evaluated. Additionally, certification of the supplier is conditional upon an on-board practical demonstration of thickness measurement as well as satisfactory reporting. (Reference document: IMO res. A.744(18) Annex A, item 7.2.1, Annex 5, item 2.3)

4.2 Special procedures related to control of supplier's relationship with the parent company

If a parent company applies to the Society for the inclusion of their nominated agents and/or subsidiaries in the certificate of approval, the parent company must have implemented a quality assurance system certified in accordance with ISO 9000 Standards. The parent company shall ensure effective controls of agents and/or subsidiaries even when the agents/subsidiaries have an equally effective quality control system complying with the ISO 9003 Standard. Such approvals shall be based upon an evaluation of the quality assurance system implemented by the parent company against minimum the ISO 9002 Standard. The Society will follow-up the adherence to this quality assurance system by performing audits on such agents or subsidiaries against the ISO 9003 Standard.

4.3 Renewal audit

Renewal or endorsement of the certificate of approval shall be made at intervals not exceeding 3 years. Verification shall be through audits confirming, or otherwise, that approved condition is being maintained. Intermediate audits may be required if found necessary by the Society. At least three months before the period of validity expires, the supplier shall apply to the Society for renewal of the certificate of approval.

5. Certificate of approval

5.1 Approval of the supplier

If the submitted documentation and the surveyor's audit and the practical demonstration are found satisfactory, the supplier will receive a certificate of approval. The certificate of approval will be published on the Internet at <http://exchange.dnv.com> and in Register No. 102 Approved Service Suppliers, issued annually.

6. Information on alteration to the certified service operation system

6.1 Alteration

In cases where any alteration to the certified service operation system of the supplier is made, such alteration is to be reported immediately to the Society. A re-audit may be required when deemed necessary by the Society.

7. Cancellation of the certificate of approval

7.1 Right to cancel

The Society reserves the right to cancel the certificate of approval in the following cases:

- Where the service was improperly carried out or the results were improperly reported
- Where a surveyor finds deficiencies in the approved service operation system of the supplier and appropriate corrective action is not taken
- Where the supplier fails to give information of any alteration, as given in 6.1
- Where an intermediate audit, if requested as described in 4.3, has not been carried out
- Where wilful acts or omissions are ascertained.

7.2 Information

The Society reserves the right to inform interested parties on cancellation of the certificate of approval.

7.3 Re-approval

A supplier that has had the certificate of approval cancelled may apply for re-approval after a period of six (6) months. This possibility is not open if the cancellation was based on a grave fault, such as a violation of code of conduct.

8. References

- IMO res. A.744(18) Annex A, item 7.2.1, Annex 5, item 2.3
- DNV Rules for Classification of Ships, MOUs and HSLC Pt.1 Ch.1 Sec 3 A401
- DNV Rules for Classification of Ships Pt.7 Ch.2
- DNV Guidelines No. 10

Appendix D Mapping of areas with substantial corrosion

D.1 Main Class (all ships) - Mapping of Substantial Corrosion

Rules Pt.7 Ch.2 Sec.2 Table D4 Guidance for extent of thickness measurements at those areas of substantial corrosion (IACS UR Z7)		
<i>Structural member</i>	<i>Extent of measurement</i>	<i>Pattern of measurement</i>
Plating	Suspect area and adjacent plates	5 point pattern over 1 m ²
Stiffeners	Suspect area	3 measurements each in line across web and flange

D.2 Bulk Carriers - Mapping of Substantial Corrosion

Rules Pt.7 Ch.2 Sec.3 Table F3 Requirements for extent of thickness measurements at those areas of substantial corrosion. Renewal survey of bulk carriers within the cargo area (IACS UR Z10.2)			
	<i>Structural member</i>	<i>Extent of measurement</i>	<i>Pattern of measurement</i>
Shell plating	1. Bottom and side shell plating	a) Suspect plate, plus four adjacent plates b) See other tables for particulars on gauging in way of tanks and cargo holds	a) 5 point pattern for each panel between longitudinals
	2. Bottom and side shell longitudinals	Minimum of three longitudinals in way of Suspect Areas	3 measurements in line across web 3 measurements on flange
Transverse bulkheads in cargo holds	1. Lower stool	a) Transverse band within 25 mm of welded connection to inner bottom b) Transverse band within 25 mm of welded connection to shelf plate	a) 5 point between stiffeners over 1 m length b) 5 point between stiffeners over 1 m length
	2. Transverse bulkhead	a) Transverse band within 250 mm of top of shedder plate or hopper plate b) Transverse band at approximately mid height c) Transverse band at part of bulkhead adjacent to upper deck or below upper stool shelf plate (for those ships fitted with upper stools)	a) 5 point pattern over 1 m ² of plating b) 5 point pattern over 1 m ² of plating c) 5 point pattern over 1 m ² of plating
Deck structure, including hatch covers and coamings	1. Cross deck strip plating	Suspect cross deck strip plating	a) 5 point pattern between under deck stiffeners over 1 m length
	2. Under deck stiffeners	a) Transverse members b) Longitudinal member	a) 5 point pattern at each end and mid span b) 5 point pattern on both web and flange
	3. Hatch covers	a) Skirt each side and ends, 3 locations b) 3 longitudinal bands, outboard strakes (2) and centreline strake(1)	a) 5 point pattern at each location b) 5 point measurement each band
	4. Hatch coamings	Each side and end of coaming, one band lower 1/3, one band upper 2/3 of coaming	5 point measurement each band i.e. end or side coaming

	5. Topside water ballast tanks	<ul style="list-style-type: none"> a) Watertight transverse bulkheads <ul style="list-style-type: none"> i) lower 1/3 of bulkhead ii) upper 2/3 of bulkhead iii) stiffeners b) 2 representative swash transverse bulkheads <ul style="list-style-type: none"> i) lower 1/3 of bulkhead ii) upper 2/3 of bulkhead iii) stiffeners c) 3 representative bays of slope plating <ul style="list-style-type: none"> i) lower 1/3 of tank ii) upper 2/3 of tank d) Longitudinals, suspect and adjacent 	<ul style="list-style-type: none"> a) <ul style="list-style-type: none"> i) 5 point pattern over 1 m² of plating ii) 5 point pattern over 1 m² of plating iii) 5 point pattern over 1 m length b) <ul style="list-style-type: none"> i) 5 point pattern over 1 m² of plating ii) 5 point pattern over 1 m² of plating iii) 5 point pattern over 1 m length c) <ul style="list-style-type: none"> i) 5 point pattern over 1 m² of plating ii) 5 point pattern over 1 m² of plating d) 5 point pattern both web and flange over 1 m length
	6. Main deck plating	Suspect plates and adjacent (4)	5 point pattern over 1 m ² of plating
	7. Main deck longitudinals	Minimum of 3 longitudinals where plating measured	5 point pattern on both web and flange over 1 m length
	8. Web frames or transverses	Suspect plates	5 point pattern over 1 m ²
Double bottom and hopper structure	1. Inner and double bottom plating	Suspect plate plus all adjacent plates	5 point pattern for each panel between longitudinals over 1 m length
	2. Inner and double bottom longitudinals	Three longitudinals where plates measured	+ 3 measurements in line across web and 3 measurements on flange
	3. Longitudinal girders or transverse floors	b) Suspect plates	b) 5 point pattern over about 1 m ²
	4. Watertight bulkheads (WT floors)	<ul style="list-style-type: none"> a) lower 1/3 of tank b) upper 2/3 of tank 	<ul style="list-style-type: none"> a) 5 point pattern over 1 m² of plating b) 5 point pattern alternate plates over 1 m² of plating
	5. Web frames	Suspect plate	5 point pattern over 1 m ² of plating
	6. Bottom and shell longitudinals	Minimum of three longitudinals in way of suspect area	<ul style="list-style-type: none"> a) 3 measurements in line across web b) 3 measurements on flange
Cargo holds	1. Side shell frames	Suspect frame and each adjacent frame	<ul style="list-style-type: none"> a) At each end and mid span: 5 point pattern of both web and flange b) 5 point pattern within 25 mm of welded attachment to both shell and lower slope plate

D.3 Single Hull Oil Tankers - Mapping of Substantial Corrosion

Rules Pt.7 Ch.2 Sec.3 Table G6 Requirements for extent of thickness measurement at those areas of substantial corrosion. Renewal survey of single hull oil tankers, ore/oil ships within the cargo tank length			
	<i>Structural member</i>	<i>Extent of measurement</i>	<i>Pattern of measurement</i>
Bottom structure	1. Bottom plating	Minimum of 3 bays across tank, including aft bay. Measurements around and under all bell mouths	5 point pattern for each panel between longitudinals and webs
	2. Bottom longitudinals	Minimum of 3 longitudinals in each bay where bottom plating measured	3 measurements in line across flange and 3 measurements on vertically web
	3. Bottom girders and brackets	At fore and aft transverse bulkhead bracket toes and in centre of tanks	Vertical line of single measurements on web plating with one measurement between each panel stiffener, or a minimum of three measurements. Two measurements across face flat. 5 point pattern on girder/bulkhead brackets
	4. Bottom transverse webs	3 webs in bays where bottom plating measured, with measurements at both ends and middle	5 points pattern over 2 m ² area. Single measurements on face flat
	5. Panel stiffening	Where available	Single measurements
Deck structure	1. Deck plating	Two bands across tank	Minimum of three measurements per plate per band
	2. Deck longitudinals	Minimum of 3 longitudinals in each of two bays	3 measurements in line vertically on webs, and 2 measurements on flange (if fitted)
	3. Deck girders and brackets	At fore and aft transverse bulkhead, bracket toes and in centre of tanks	Vertical line of single measurements on web plating with one measurement between each panel stiffener, or a minimum of three measurements. Two measurements across face flat. 5 point pattern on girder/bhd brackets
	4. Deck transverse webs	Minimum of two webs with measurements at middle and both ends of span	5 points pattern over about 2 m ² area. Single measurements on face flat
	5. Panel stiffening	Where available	Single measurements
Shell and longitudinal bulkheads	1. Deckhead and bottom strakes, and strakes in way of stringer platforms	Plating between each pair of longitudinals in a minimum of 3 bays	Single measurement
	2. All other strakes	Plating between every 3rd pair of longitudinals in same 3 bays	Single measurement
	3. Longitudinals-deckhead and bottom strakes	Each longitudinal in same 3 bays	3 measurements across web and 1 measurement on flange
	4. Longitudinals - all others	Every third longitudinal in same 3 bays	3 measurements across web and 1 measurement on flange
	5. Longitudinals - bracket	Minimum of three at top middle and bottom of tank in same 3 bays	5 point pattern over area of bracket
	6. Web frames and cross ties	3 webs with minimum of three locations on each web, including in way of cross tie connections	5 point pattern over about 2 m ² area, plus single measurements on web frame and cross tie face flats
Transverse bulkheads and swash bulkheads	1. Deckhead and bottom strakes, and strakes in way of stringer platforms	Plating between pair of stiffeners at three locations - approximately 1/4, 1/2 and 3/4 width of tank	5 points pattern between stiffeners over 1 m length
	2. All other strakes	Plating between pair of stiffeners at middle location	Single measurement
	3. Strakes in corrugated bulkheads	Plating for each change of scantling at centre of panel and at flange or fabricated connection	5 point pattern over about 1 m ² of plating

	4. Stiffeners	Minimum of three typical stiffeners	For web, 5 point pattern over span between bracket connections (2 measurements across web at each bracket connection, and one at centre of span). For flange, single measurements at each bracket toe and at centre of span
	5. Brackets	Minimum of three at top, middle and bottom of tank	5 point pattern over area of bracket
	6. Deep webs and girders	Measurements at toe of bracket and at centre of span	For web, 5 point pattern over about 1 m ² . 3 measurements across face flat
	7. Stringer platforms	All stringers with measurements at both ends and middle	5 point pattern over 1 m ² of area plus single measurements near bracket toes and on face flats
(IACS UR Z10.1)			

D.4 Double Hull Oil Tankers - Mapping of Substantial Corrosion

Rules Pt.7 Ch.2 Sec.3 Table G7 Requirements for extent of thickness measurement at those areas of substantial corrosion. Renewal survey of double hull oil tankers within the cargo area length		
<i>Bottom, inner bottom and hopper structure</i>		
<i>Structural member</i>	<i>Extent of measurement</i>	<i>Pattern of measurement</i>
Bottom, inner bottom and hopper structure plating	Minimum of three bays across double bottom tank, including aft bay Measurements around and under all suction bell mouths	5-point pattern for each panel between longitudinals and floors
Bottom, inner bottom and hopper structure longitudinals	Minimum of three longitudinals in each bay where bottom plating measured	Three measurements in line across flange and three measurements on vertical web
Bottom girders, including the watertight ones	At fore and aft watertight floors and in centre of tanks	Vertical line of single measurements on girder plating with one measurement between each panel stiffener, or a minimum of three measurements
Bottom floors, including the watertight ones	Three floors in bays where bottom plating measured, with measurements at both ends and middle	5-point pattern over two square metre area
Hopper structure web frame ring	Three floors in bays where bottom plating measured	5-point pattern over one square metre of plating. Single measurements on flange
Hopper structure transverse watertight bulkhead or swash bulkhead	Lower 1/3 of bulkhead	5-point pattern over one square metre of plating
	Upper 2/3 of bulkhead	5-point pattern over two square metre of plating
	Stiffeners (minimum of three)	For web, 5-point pattern over span (two measurements across web at each end and one at centre of span). For flange, single measurements at each end and centre of span
Panel stiffening	Where applicable	Single measurements
(IACS UR Z10.4)		

Rules Pt.7 Ch.2 Sec.3 Table G8 Requirements for extent of thickness measurement at those areas of substantial corrosion. Renewal survey of double hull oil tankers within the cargo area length		
<i>Deck structure</i>		
<i>Structural member</i>	<i>Extent of measurement</i>	<i>Pattern of measurement</i>
Deck plating	Two transverse bands across tank	Minimum of three measurements per plate per band

Deck longitudinals	Every third longitudinal in each of two bands with a minimum of one longitudinal	Three measurements in line vertically on webs and two measurements on flange (if fitted)
Deck girders and brackets (usually in cargo tanks only)	At fore and aft transverse bulkhead, bracket toes and in centre of tanks	Vertical line of single measurements on web plating with one measurement between each panel stiffener, or a minimum of three measurements. Two measurements across flange. 5-point pattern on girder/bulkhead brackets
Deck transverse webs	Minimum of two webs, with measurements at both ends and middle of span	5-point pattern over one square metre area. Single measurements on flange
Vertical web and transverse bulkhead in wing ballast tank (two metres from deck)	Minimum of two webs, and both transverse bulkheads	5-point pattern over one square metre area
Panel stiffening	Where applicable	Single measurements
(IACS UR Z10.4)		

Rules Pt.7 Ch.2 Sec.3 Table G9 Requirements for extent of thickness measurement at those areas of substantial corrosion. Renewal survey of double hull oil tankers within the cargo area length		
<i>Structure in wing ballast tanks</i>		
<i>Structural member</i>	<i>Extent of measurement</i>	<i>Pattern of measurement</i>
Side shell and longitudinal bulkhead plating: — upper strake and strakes in way of horizontal girders — all other strakes	— Plating between each pair of longitudinals in a minimum of three bays (along the tank) — Plating between every third pair of longitudinals in same three bays	— Single measurement — Single measurement
Side shell and longitudinal bulkhead longitudinals on: — upper strake — all other strakes	— Each longitudinal in same three bays — Every third longitudinal in same three bays	— 3 measurements across web and 1 measurement on flange — 3 measurements across web and 1 measurement on flange
Longitudinals - brackets	Minimum of three at top, middle and bottom of tank in same three bays	5-point pattern over area of bracket
Vertical web and transverse bulkheads (excluding deckhead area): — strakes in way of horizontal girders — other strakes	— Minimum of two webs and both transverse bulkheads — Minimum of two webs and both transverse bulkheads	— 5-point pattern over approx. two square metre area — two measurements between each pair of vertical stiffeners
Horizontal girders	Plating on each girder in a minimum of three bays	Two measurements between each pair of longitudinal girder stiffeners
Panel stiffening	Where applicable	Single measurements
(IACS UR Z10.4)		

Rules Pt.7 Ch.2 Sec.3 Table G10 Requirements for extent of thickness measurement at those areas of substantial corrosion. Renewal survey of double hull oil tankers within the cargo area length		
<i>Longitudinal bulkheads in cargo tanks</i>		
<i>Structural member</i>	<i>Extent of measurement</i>	<i>Pattern of measurement</i>
Deckhead and bottom strakes, and strakes in way of the horizontal stringers of transverse bulkheads	Plating between each pair of longitudinals in a minimum of three bays	Single measurement

All other strakes	Plating between every third pair of longitudinals in same three bays	Single measurement
Longitudinals on deckhead and bottom strakes	Each longitudinal in same three bays	Three measurements across web and one measurement on flange
All other longitudinals	Every third longitudinal in same three bays	Three measurements across web and one measurement on flange
Longitudinals - brackets	Minimum of three at top, middle and bottom of tank in same three bays	5-point pattern over area of bracket
Web frames and cross ties	Three webs with minimum of three locations on each web, including in way of cross tie connections	5-point pattern over approximately two square metre area of webs, plus single measurements on flanges of web frame and cross ties
Lower end brackets (opposite side of web frame)	Minimum of three brackets	5-point pattern over approximately two square metre area of brackets, plus single measurements on bracket flanges
(IACS UR Z10.4)		

Rules Pt.7 Ch.2 Sec.3 Table G11 Requirements for extent of thickness measurement at those areas of substantial corrosion. Renewal survey of double hull oil tankers within the cargo area length		
<i>Transverse watertight and swash bulkheads in cargo tanks</i>		
<i>Structural member</i>	<i>Extent of measurement</i>	<i>Pattern of measurement</i>
Upper and lower stool, where fitted	<ul style="list-style-type: none"> — Transverse band within 25 mm of welded connection to inner bottom/deck plating — Transverse band within 25 mm of welded connection to shelf plate 	5-point pattern between stiffeners over 1 m length
Deckhead and bottom strakes, and strakes in way of horizontal stringers	Plating between pair of stiffeners at three locations: approximately 1/4, 1/2 and 3/4 width of tank	5-point pattern between stiffeners over 1 m length
All other strakes	Plating between pair of stiffeners at middle location	Single measurement
Strakes in corrugated bulkheads	Plating for each change of scantling at centre of panel and at flange of fabricated connection	5-point pattern over about 1 m ² of plating
Stiffeners	Minimum of three typical stiffeners	For web, 5-point pattern over span between bracket connections (two measurements across web at each bracket connection and one at centre of span). For flange, single measurements at each bracket toe and at centre of span
Brackets	Minimum of three at top, middle and bottom of tank	5-point pattern over area of bracket
Horizontal stringers	All stringers with measurements at both ends and middle	5-point pattern over 1 m ² area, plus single measurements near bracket toes and on flanges
(IACS UR Z10.4)		

D.5 Tankers for Chemicals - Mapping of substantial corrosion

Table K4 Requirements for extent of thickness measurements at those areas of substantial corrosion. Renewal survey of chemical tankers			
	<i>Structural member</i>	<i>Extent of measurement</i>	<i>Pattern of measurement</i>
Double bottom and hopper structure	1. Inner bottom plating and bottom plating	Suspect plate plus all adjacent plates. Measurements around and under all bell mouths and pump wells	5 point pattern for each panel between longitudinals over 1 m length

	2. Inner bottom and bottom longitudinals	Three longitudinals where plates measured	3 measurements in line across flange and 3 measurements on vertically web
	3. Longitudinal girders or transverse floors	Suspect plates	5 point pattern over about 1 m ² a) 5 point pattern over about 1 m ² b) 5 point pattern alternate plates over 1 m ² of plating
	4. Watertight bulkheads (WT floors)	a) Lower 1/3 of tank b) Upper 2/3 of tank	5 point pattern
	5. Web frames	Suspect plate	
Deck structure ¹⁾	1. Deck plating	Two bands across tank	Minimum of three measurements per plate per band
	2. Deck longitudinals	Minimum of 3 longitudinals in each of two bays	3 measurements in line vertically on webs, and 2 measurements on flange (if fitted)
	3. Deck girders and brackets	At fore and aft transverse bulkhead, bracket toes and in centre of tanks	Vertical line of single measurements on web plating with one measurement between each panel stiffener, or a minimum of three measurements. Two measurements across face flat. 5 point pattern on girder/bulkhead brackets
	4. Deck transverse webs	Minimum of two webs with measurements at middle and both ends of span	5 point pattern over about 2 m ² areas. Single measurements of face flat
	5. Panel stiffening	Where available	Single measurements
Shell and longitudinal bulkheads	1. Deckhead and bottom strakes, and strakes in way of stringer platforms	Plating between each pair of longitudinals in a minimum of 3 bays.	Single measurements
	2. All other strakes	Plating between every 3rd pair of longitudinals in same 3 bays	Single measurements
	3. Longitudinals - deckhead and bottom strakes	Each longitudinal in same 3 bays	3 measurements across web and 1 measurement on flange
	4. Longitudinals - all others	Every third longitudinal in same 3 bays	3 measurements across web and 1 measurement on flange
	5. Longitudinals - brackets	Minimum of three at top middle and bottom of tank in same 3 bays	5 point pattern over area of bracket
	6. Web frames and cross ties	3 webs with minimum of three locations on each web, including in way of cross tie connections	5 point pattern over about 2 m ² area, plus single measurements on web frame and cross tie face flats
1) For tanks where Substantial Corrosion covers more than 20% of the deck surface, the whole deck structure including longitudinals and web frames above this tank, should be mapped as if they were areas with substantial corrosion.			
(IACS UR Z10.3)			

Appendix E Example of UTM report front page

Ultrasonic Thickness Measurement Report

Report number :

General particulars :

Ship's name :

Type of ship :

Class identity no.:

Port of registry :

Deadweight :

Date of build :

Classification society :

Measurements performed by :

Thickness measurement company certified by :

Certificate no.:

Certificate valid from : To:

Place of measurements :

First date of measurements :

Last date of measurements :

Type of surveyy :

Type of measurement equipment :

Qualification of operator :

<p>Names of Operators :</p> <p>Signature of Operators :</p> <p>Company's official stamp :</p> <p>Date :</p>	<p><u>Verified and evaluated :</u></p> <p>Signature of Class surveyor :</p> <p>Name of class surveyor :</p> <p>Classification society official stamp :</p>
--	---

Appendix F - Calculation of average thickness reduction in deck and bottom. Verification of longitudinal strength

F1 General

This appendix is a guideline on how to verify a ship's longitudinal strength, i.e. estimate average corrosion reduction in deck and bottom, as required for vessels having had a transverse section measured with UTM as part of the renewal survey scope. The calculation shall either be made by attending surveyor, or by the service supplier doing the thickness measurements, with the surveyor verifying the results.

It is not necessary to calculate the ship's section modulus or the cross section's moment of inertia in order to verify the longitudinal strength. For a quick approximation, a quick "adding up" of cross section areas, as shown in the following example, is sufficient for the verification of the longitudinal strength in the field. Only if the calculated reduction percentage gets close to 10% (or 5%, if so stated in the heading of the minimum thickness list), is it necessary to contact MTPNO864 for a more accurate approximation of actual loss of longitudinal strength. It is of no less importance that the surveyors carry out this approximation whenever a complete, transverse section is measured, as it forms the very basis for the minimum thickness list.

If the steel in plates or longitudinals is mild steel or high strength steel has no influence on the result. The thickness reduction of HS steel and mild steel may be added into one figure.

The ship's main drawings shall be used to find as-built thickness values where no min. thickness list is available.

For tankers above 130 m length, DNV will upon request send electronically an Excel sheet for average corrosion calculation/reporting, including original thickness values for applicable area.

F2 Example

For illustration, only half of the ship's breadth is included in the calculation below. When doing such verification in real life, however, one should calculate the average thickness reduction over the whole breadth, from side to side (see Fig.2). In the bottom one should calculate over the whole breadth, from bilge to bilge. As shown below, it is enough to calculate the average area reduction for the deck (or the bottom) itself, even if some of the minimum thickness lists mention the upper or lower 15% of the sides and longitudinal bulkhead as "upper area" or "lower area". However, it's not wrong to include the upper or lower 15%, either.

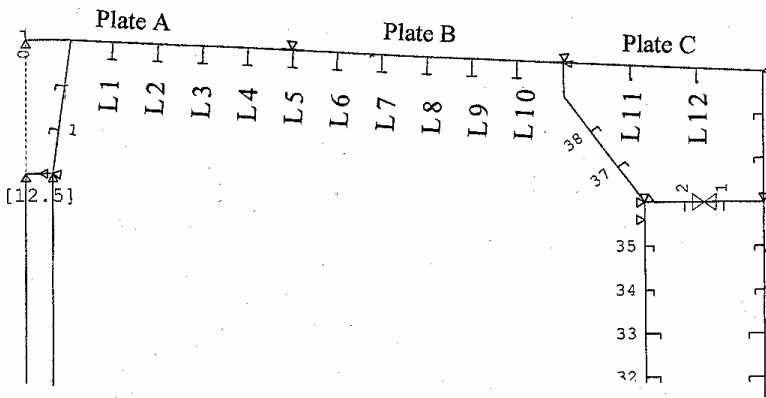

Fig.1

Deck Area, Plates :

Plates	Plate A	Plate B	Plate C
Length	4m	4m	3m
T _{orig}	16mm	15mm	14mm
T _{measured}	15mm	14,5m	13mm

Total original area, Plates : $4000\text{mm} \cdot 16\text{mm} + 4000\text{mm} \cdot 15\text{mm} + 3000\text{mm} \cdot 14\text{mm} = 166\,000\text{mm}^2$

Measured area, Plates : $4000\text{mm} \cdot 15,0\text{mm} + 4000\text{mm} \cdot 14,5\text{mm} + 3000\text{mm} \cdot 13\text{mm} = 157\,000\text{mm}^2$

Profiles :

Profiles	Original dimensions	Measured thickness, web	Measured thickness, flange
L1	300*14 + 150*20	12,8	19,0
L2	300*14 + 150*20	12,5	18,8
L3	300*14 + 150*20	13,0	18,9
L4	300*14 + 150*20	11,5	19,2
L5	300*14 + 150*20	12,0	17,0
L6	300*14 + 150*20	13,5	20,2
L7	300*14 + 150*20	14,0	20,0
L8	300*14 + 150*20	14,0	18,8
L9	300*14 + 150*20	14,5	19,5
L10	300*14 + 150*20	13,0	19,0
L11	250*16mm (HP Bulb)	15,2	N/A
L12	250*16mm (HP Bulb)	14,9	N/A

Total original area, Profiles : 300*14 + 150*20 +300*14 + 150*20 +300*14 + 150*20 +300*14 + 150*20 +300*14 + 150*20 +300*14 + 150*20 +300*14 + 150*20 +300*14 + 150*20 +300*14 + 150*20 +300*14 + 150*20 +250*16 (approx) +250*16 (approx) = 80 000 mm²

Total measured area, Profiles : 300*(12,8+12,5+13,0+11,5+12,0+13,5+14,0+14,0+14,5+13,0) +150*(19,0+18,8+18,9+19,2+17,0+20,2+20,0+18,8+19,5+19,0) +250*15,2 +250*14,9 = 75 325 mm²

Total original area = Total original area plates + Total original area profiles = 166 000mm² +80 000mm² = 246 000 mm²

Total measured area = Total measured area plates + total measured area profiles = 157 000mm² + 75 325mm² = 232 325 mm²

$$\text{Total area reduction} = \frac{246\ 000 - 232\ 325}{246\ 000} \cdot 100\% = \underline{5,6\%}$$

): If this was the only section to be measured in a ship with a maximum average corrosion limit of 10%, there would not be any problem. The surveyor could just state “average corrosion verified to be below 10%” in the inspection report. However, if the ship’s minimum thickness list has maximum 5% average corrosion in the deck area stated on the front page, then the surveyor shall be notified immediately. The ship could have so much corrosion, that it would need to have the minimum thickness list revised. The bottom should be verified the same way.

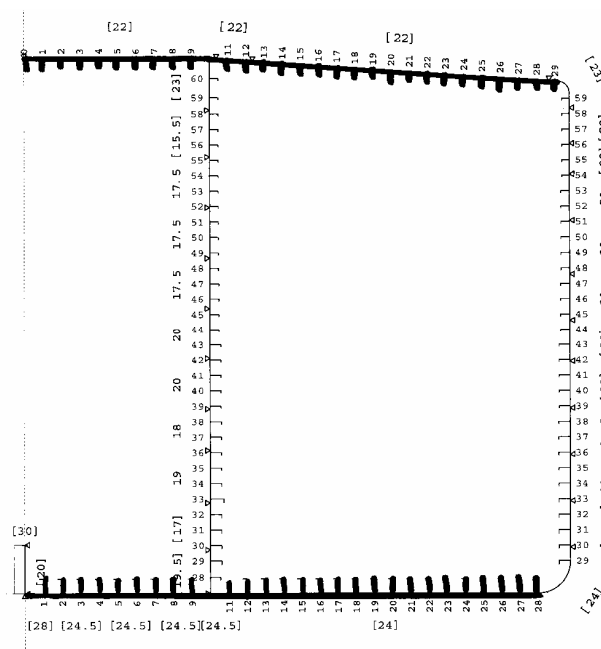

Fig.2 - Areas to be verified

Appendix G Guidelines for measurements of side frames in bulk carriers

Annex V - Guidelines for the Gauging of Side Shell Frames and Brackets in Single Side Skin Bulk Carriers required to comply with IACS Unified Requirements S31 (incorporated in DNV Rules Pt.7 Ch.1 Sec.6F).

1. General

Single Skin Bulk carriers which are to comply with the new rules (IACS Unified Requirements UR S31) will be identified with a Memo to Owner. The new rules require increased control of the side frame scantlings. To assist the Surveyor, a new minimum thickness lists will be prepared for all ships where this requirement is applicable.

2. Zones of Side Shell Frames and Brackets

For the purpose of steel renewal, sand blasting and coating, four zones A, B, C and D are defined, as shown in Figure 1. Zones A & B are considered to be the most critical zones.

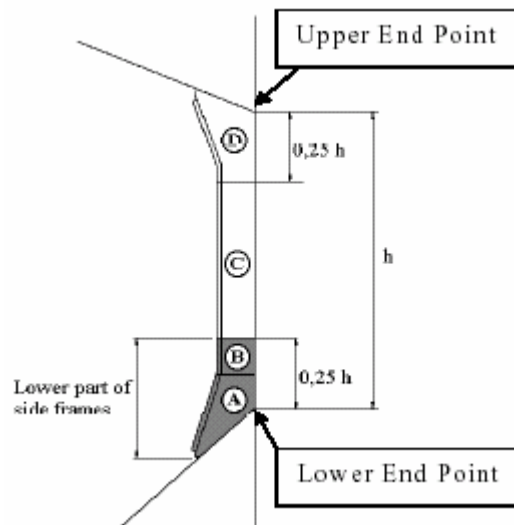

Figure 1 Zones of side shell frames and brackets

3. Pitting and grooving

Pits can grow in a variety of shapes, some of which would need to be ground before assessment.

Pitting corrosion may be found under coating blisters, which must be removed before inspection.

To measure the remaining thickness of pits or grooving the normal ultrasonic transducer (generally 10mm diameter) will not suffice. A miniature transducer (3 to 5 mm diameter) must be used. Alternatively the gauging firm must use a pit gauge to measure the depth of the pits and grooving and calculate the remaining thickness.

3.1 Assessment based upon Area

This is the method specified in S31.2.5 and is based upon the intensity determined from Figure 2 below.

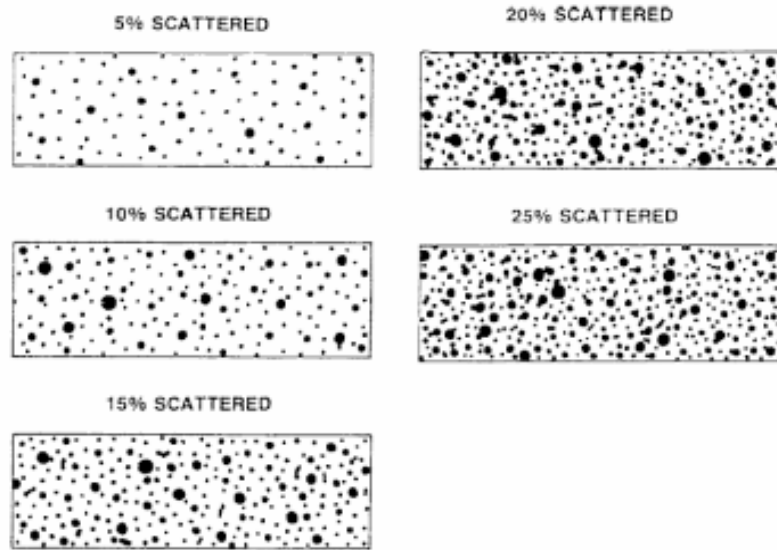

Figure 2 Pitting intensity diagrams (from 5% to 25% intensity)

If pitting intensity is higher than 15% in an area (see Figure 2), then thickness measurements are to be taken to check the extent of the pitting corrosion. The 15% is based upon pitting or grooving on only one side of the web.

In cases where pitting is evident as defined above (exceeding 15 %) then an area of 300mm diameter or more, at the most pitted part of the frame, is to be cleaned to bare metal, and the thickness measured in way of the five deepest pits within the cleaned area. The least thickness measured in way of any of these pits is to be taken as the thickness to be recorded.

The minimum acceptable remaining thickness in any pit or groove is equal to:

- 75% of the as built thickness, for pitting or grooving in the cargo hold side frame webs and flanges
- 70% of the as built thickness, for pitting or grooving in the side shell, hopper tank and topside tank plating attached to the cargo hold side frame, over a width up to 30mm from each side of it.

4. Gauging methodology

Numbers of side frames to be measured are equivalent to those of Renewal Survey or Intermediate Survey corresponding to the ship’s age. Representative thickness measurements are to be taken for each zone as specified below.

Special consideration to the extent of the thickness measurements may be given by the Classification Society, if the structural members show no thickness diminution with respect to the as built thicknesses and the coating is found in "as-new" condition (i.e., without breakdown or rusting).

Where gauging readings close to the criteria are found, the number of hold frames to be measured is to be increased.

The Planning Document for vessels where IACS UR S31 apply, will include an additional T-min list valid for the side frames, or the list will be provided separately.

If renewal or other measures according to S31 are to be applied on individual frames in a hold, then all frames in that hold are to be gauged.

There is a variety of construction methods used for side shell frames in bulk carriers. Some have faceplates (T sections) on the side shell frames, some have flanged plates and some have bulb plates. The use of faceplates and flanged sections is considered similar for gauging purposes in that both the web and faceplate or web and flange plate are to be gauged.

If bulb plate has been used, then the web of the bulb plate is to be gauged in the normal manner and the sectional modulus has to be specially considered if required. ***The provided T-min list will normally indicate cases where sectional modulus may be a problem.***

4.1 Gaugings of Web plating for Zones A, B & D

The gauging pattern for Zones A, B & D are to be a five point pattern. See figure 3. The 5 point pattern is to be over the depth of the web and the same area vertically. The gauging report is to reflect the average reading.

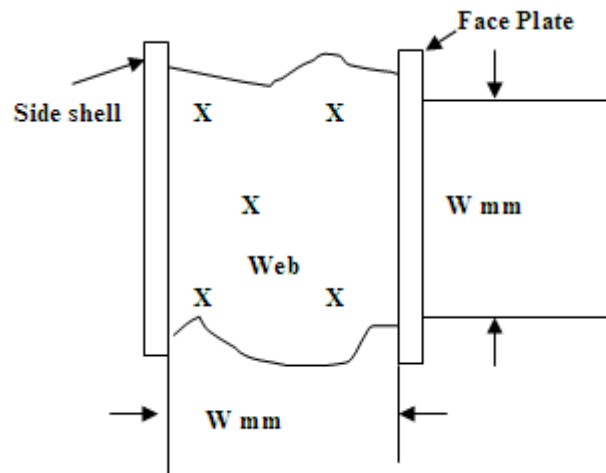

Fig.3 Five point pattern

4.2 Gaugings of Web plating for Zone C

Depending upon the condition of the web in way of Zone C, the web may be measured by taking 3 readings over the length of Zone C and averaging them. The average reading is to be compared with the allowable thickness. If the web plating has general corrosion then this pattern should be expanded to a five point pattern as noted above.

4.3 Gaugings of flanges for all Zones

At least 2 readings on the flange/faceplate are to be taken in way of section a) and b), see figure 4. At least one reading of the attached shell plating is to be taken on each side of the frame (i.e. fore and aft) in way of section a) and section b).

At least 2 readings on the flange/faceplate are to be taken in way of one selected section within each of the zones C and D. At least one reading of the attached shell plating is to be taken on each side of the frame (i.e. fore and aft) in way of the selected sections.

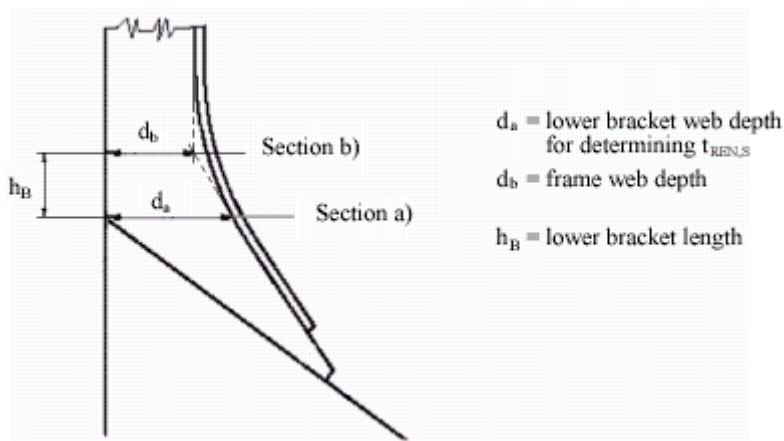
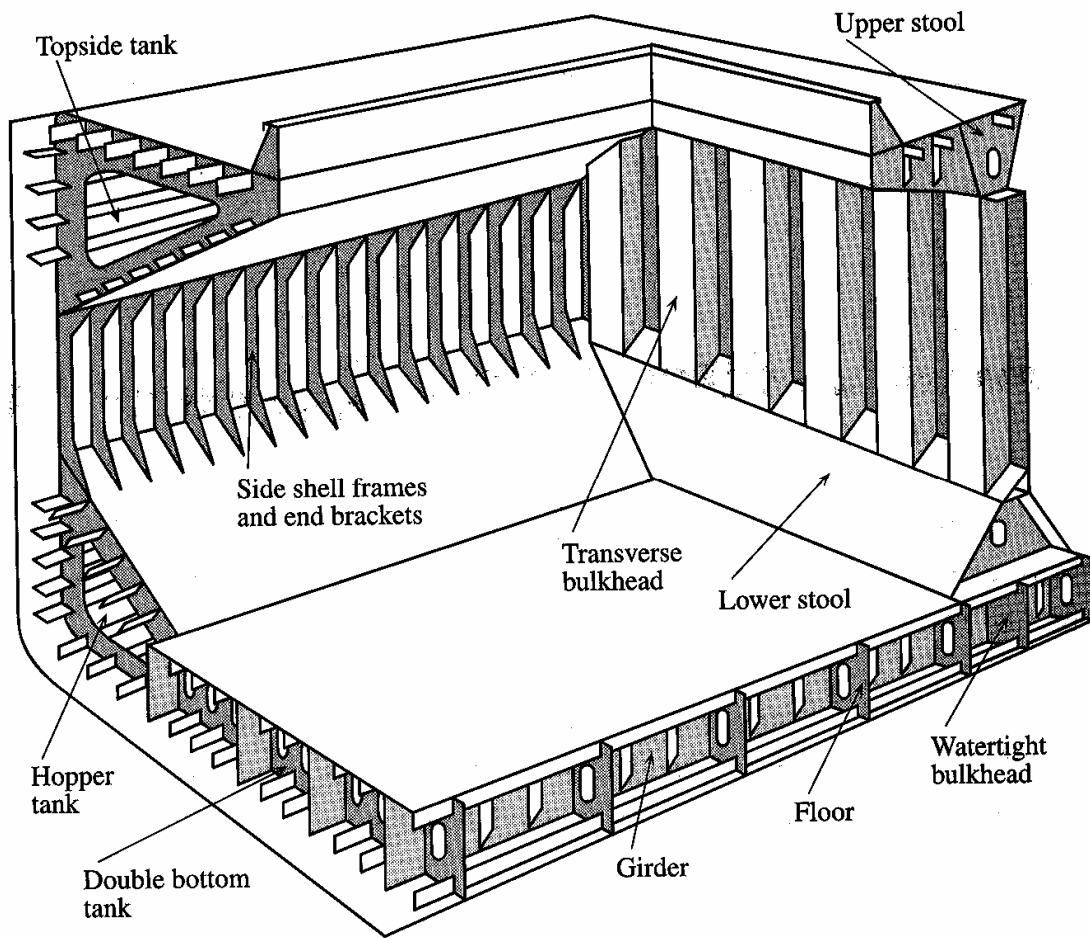

Figure 4 - Sections a) and b)

APPENDIX H GLOSSARY



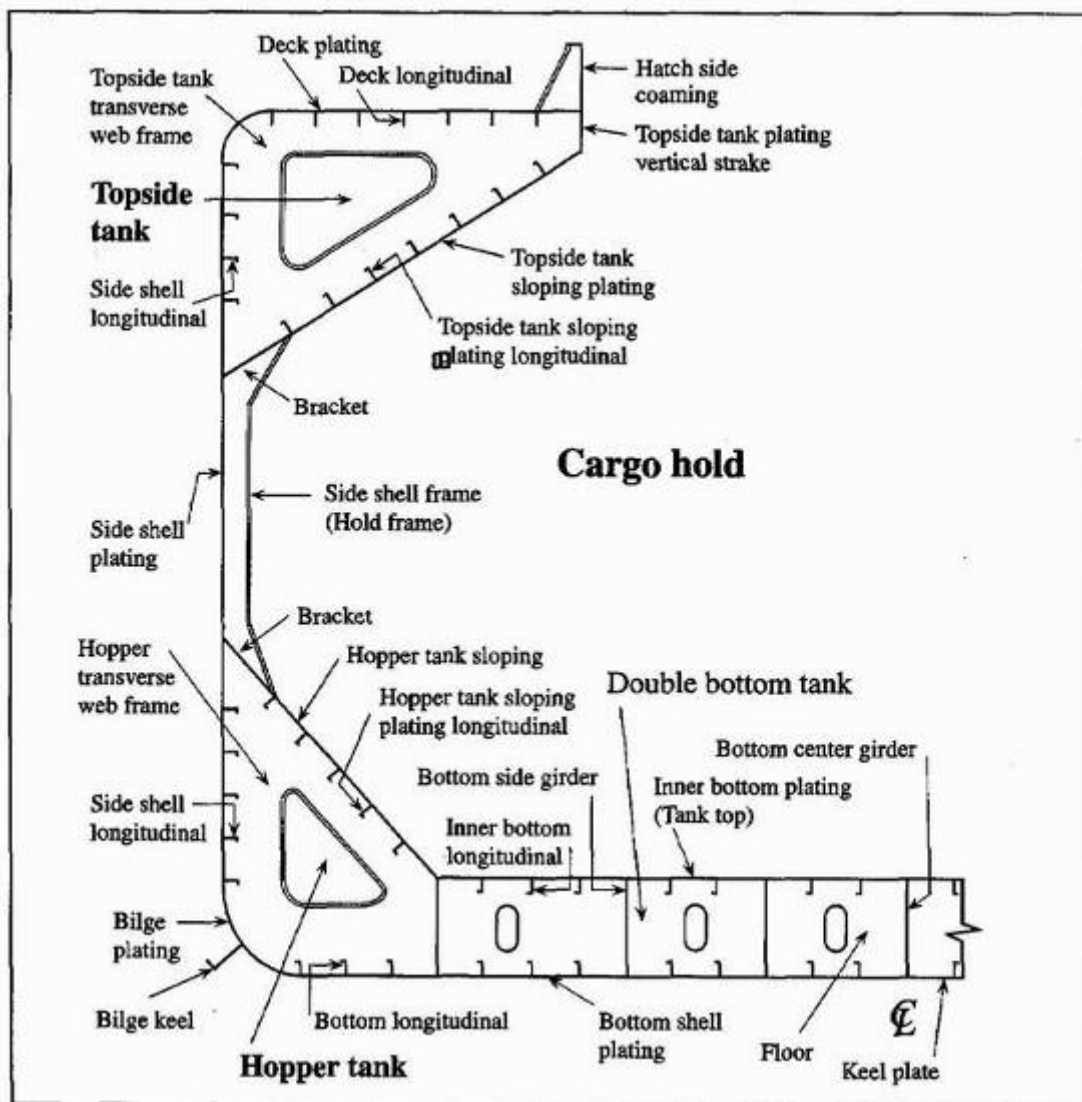
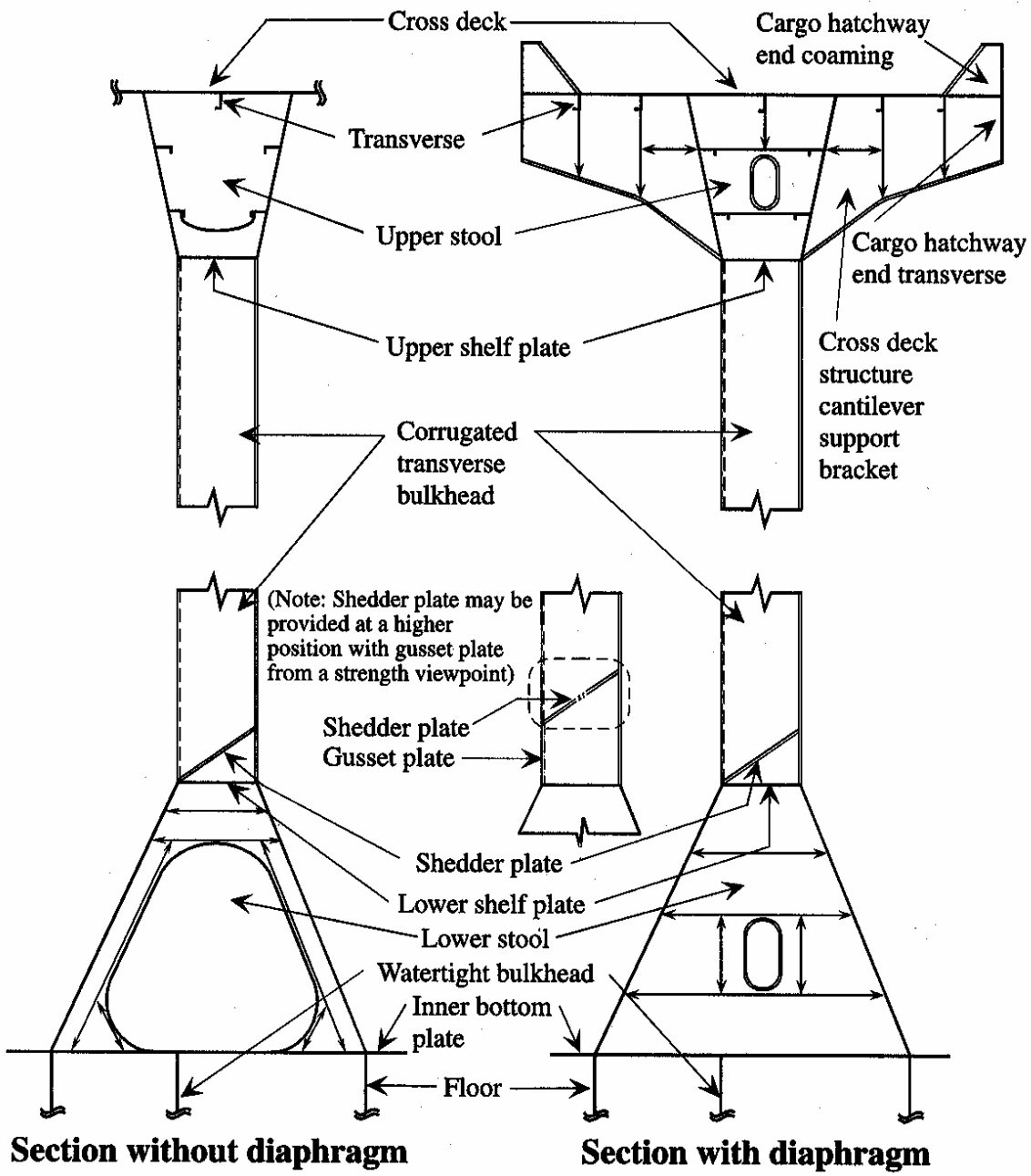

Fig. Bulk carriers



Tankers

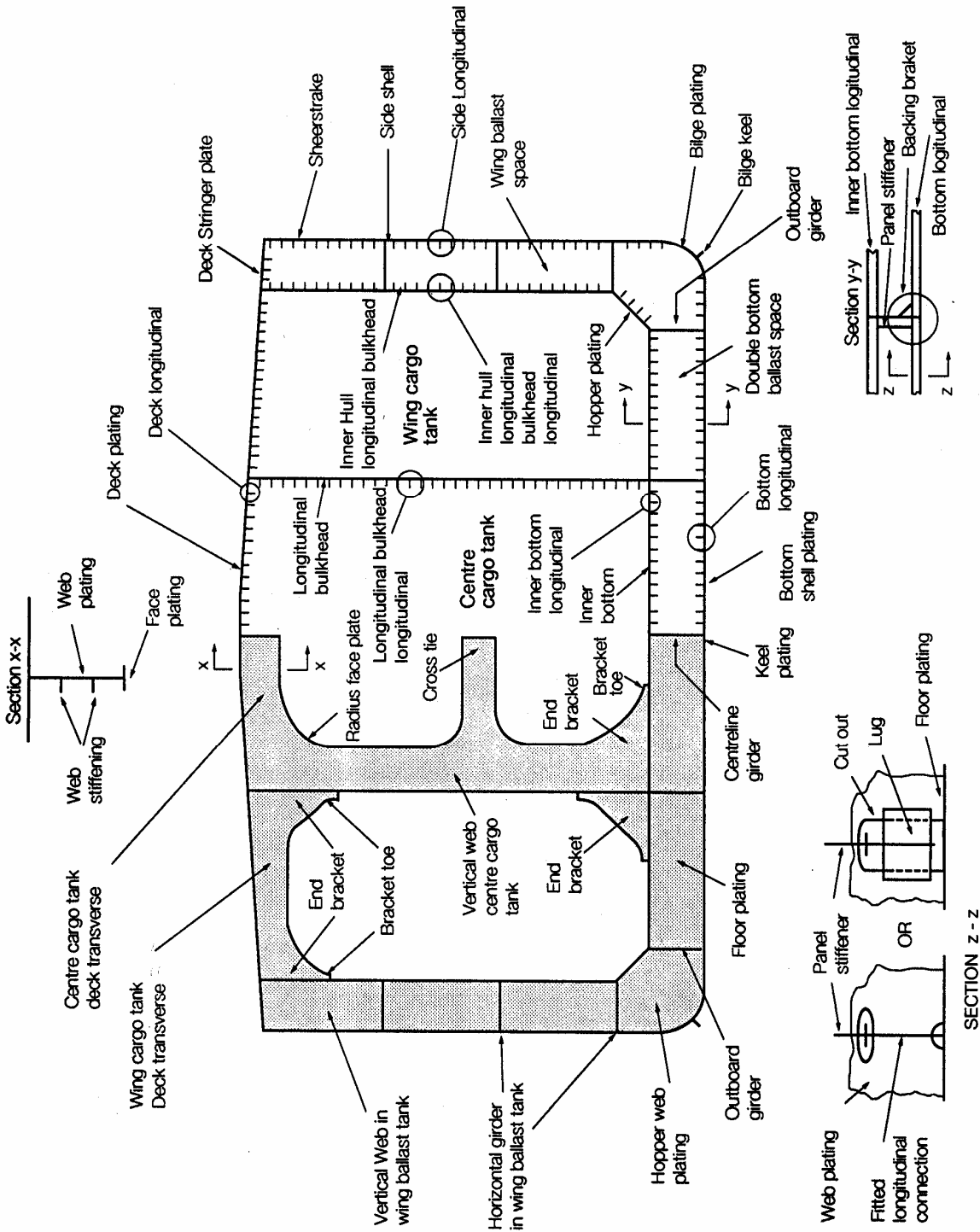
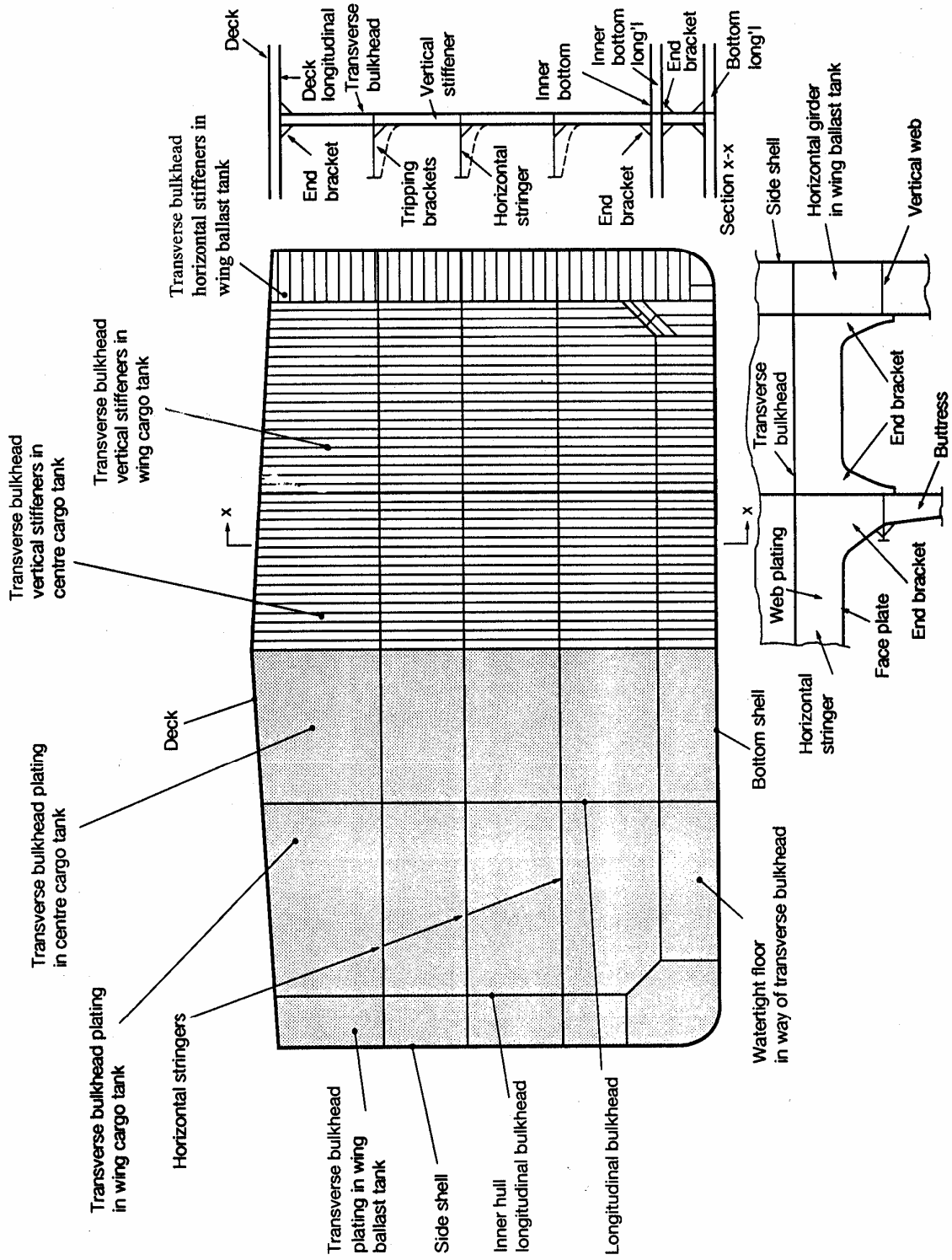

Fig. Tankers



Other terms :

See also 2. Terms and abbreviations

After Peak Bulkhead is a term applied to the first main transverse watertight bulkhead forward of the stern, or is the compartment in the narrow part of the stern aft of the last watertight bulkhead.

Bay is the area between adjacent transverse frames.

Breast Hook is a triangular plate bracket joining port and starboard side structural members at the stem.

Bulkhead Deck is the uppermost continuous deck to which transverse watertight bulkheads and shell are carried.

Bulwark is fore- and aft vertical plating immediately above the upper edge of the sheer strake.

Butt Joint is a joint between two structural members lying in the same plane. Typically a butt joint is used to describe the welded connection between two plates in the transverse direction.

Cargo Area or Cargo Length Area is that part of the vessel that contains cargo holds and cargo / slop tanks and adjacent areas including ballast tanks, fuel tanks, cofferdams, void spaces and also including deck areas throughout the entire length and breadth of the part of the ship over the mentioned spaces.

Carlings are supports usually of flat plate, welded in a fore and aft direction between transverse deck beams to prevent distortion of the plating.

Coaming is the vertical boundary of a hatch or skylight.

Cofferdams are spaces between two bulkheads or decks primarily designed as a safeguard against leakage of oil from one compartment to another.

Collision Bulkhead is the foremost main transverse watertight bulkhead.

Companion Way is a weathertight entrance leading from a ship's deck to spaces below.

Cross Deck is the area between cargo hatches.

Deep Tank is a tank extending from the bottom or inner bottom up to or higher than the lowest deck.

Duct Keel is a keel built of plates in box form extending the length of the cargo hold. It is used to house ballast and other piping leading forward which otherwise would have to run through the cargo holds.

Extensive Corrosion is an extent of corrosion consisting of hard and/or loose scale, including pitting, over 70% or more of the area under consideration, accompanied by evidence of thickness diminution.

Excessive corrosion See 2. Terms and abbreviations.

Fatigue is the tendency of materials to fracture under many repetitions of a stress considerably less than the ultimate static strength.

Forecastle is a short superstructure situated at the bow.

Forepeak is the area of the ship forward of the collision bulkhead.

Freeboard Deck is normally the uppermost complete deck exposed to weather and sea, which has permanent means of closing all openings in the weather part thereof.

Freeing Port is an opening in the bulwarks to allow water shipped on deck to run freely overboard.

Galvanizing is the deposition of zinc on to the surface of steel to provide corrosion protection by both protecting the steel from contact with the environment and giving sacrificial protection.

Girder is a collective term for primary supporting structural members.

Gunwale is the upper edge of the ship's sides.

Gusset is a triangular plate, usually fitted to distribute forces at a strength connection between two structural members.

Indent is deformation of structural members caused by out-of-plane loads like bottom slamming and bow impact forces, contact with other objects etc.

Independent Tank is a self-supporting tank and while connected to the ship's main structure, is not dependent on this structure.

Keel is the main structural member of backbone of a vessel running longitudinal along centreline of bottom.

Usually a flat plate stiffened by a vertical plate on its centreline inside the shell.

Lap Joint is a joint between two structural members that overlap each other.

Loose Scale is sheets of rust falling off if the surveyor hits the structure with his test hammer. Loose scale can best be removed by hand or power tool cleaning or a combination of these.

Midship Section is the cross section through the ship, midway between the forward and after perpendiculars.

Pipe Tunnel is the void space running in the midships fore and aft lines between the inner bottom and shell plating forming a protective space for bilge, ballast and other lines extending from the engine room to the holds.

Pinholing is tiny, deep holes exposing substrate.

Poop is the space below an enclosed superstructure at the extreme after end of a ship.

Poop Deck is the first deck above the shelter deck at after end of a vessel.

Port Light is another term for side light or side scuttle.

Scale is product of the corrosion process of steel with a porous surface layer or flakes, in volume greater than the metal from which it was formed.

Scantlings are the dimensions of a ship's structural members as girders, stiffeners and plates.

Scupper is any opening for carrying off water from a deck, either directly or through piping.

Scuttle is a small opening in a deck or elsewhere, usually fitted with a cover or lid or a door as for access to a compartment.

Seam is a joint between two structural members lying in the same plane. Typically a seam is used to describe the welded connection of two plates in the longitudinal direction.

Semi-hard Coating is a coating that dries or converts in such a way that it stays flexible although hard enough to touch and walk upon.

Shedder Plates are slanted plates fitted in dry cargo holds to prevent undesired pockets of cargo. The term is also commonly applied to slanted plates that are fitted to improve the structural stability of corrugated bulkheads and framing members.

Sheer Strake is the top strake of a ship's side shell plating.

Shop primer is a rust preventing paint for temporary protection of steel immediately after blasting for protection of the material surface from corrosion during construction and until the final paint system is applied.

Single Bottom Structure is the shell plating with stiffeners and girders below the upper turn of bilge.

Soft Coating is a coating that remains soft so that it wears off at low mechanical impact or when touched; often based on oils (vegetable or petroleum) or lanolin (sheep wool grease). Application of soft coating does generally not allow relaxation of the annual hull survey requirements of ballast tanks.

Spaces are separate compartments including holds and tanks.

Stay is a term for bulwarks and hatch coaming brackets.

Stem is the piece of bar or plating at which a vessel's outside plating terminates at her forward end.

Stern Frame is the heavy strength member in single or triple screw vessels, combining the rudder post.

Stiffener is a collective term for secondary supporting structural members.

Stool is a structure supporting cargo hold and tank bulkheads.

Strake is a course, or row, of shell, deck, bulkhead, or other plating.

Strength Deck is normally the uppermost continuous deck. After special consideration of its effectiveness, another deck may be defined as strength deck.

Stress Concentration or Stress Raiser is a term used of any notch, crack, hole, corner, groove, attachment or other interruption to smooth flow of stress and strain in structures introduces a concentration of stress.

Stress Corrosion is local corrosion that may occur when a metallic material is simultaneously exposed to both tensile stresses and a corrosive medium. Tensile stresses may be residual stresses from welding or cold-working or applied working stresses.

Stringer Plate is the outside strake of deck plating.

Structural Testing or Tank Testing is a hydrostatic test carried out to demonstrate the structural adequacy of design and tightness of tank boundaries.

Substantial Corrosion See 2. "Terms and abbreviations".

Superstructure is a decked structure on the freeboard deck extending from side to side of the ship.

Suspect Areas are locations showing substantial corrosion and/or which are considered by the Surveyor to be prone to rapid wastage.

Topside Wing Ballast tanks are ballast tanks in bulk carriers that normally stretch along the length of the ship's side and occupy the upper corners of the cargo hold.

Void is an enclosed empty space in a vessel, i.e., cofferdam.

Transverse Section includes, for thickness measurement purposes, all longitudinal members such as plating, longitudinals and girders at the deck, side, bottom, inner bottom and longitudinal bulkheads. For transversely framed ships, a transverse section includes adjacent frames and their end connections in way of transverse section. Also called Girth belt.

Wash Bulkhead is a perforated or partial bulkhead in a tank.

Watertight Bulkhead is a collective term for transverse bulkheads required for subdivision of the hull into watertight compartments.

Weathertight means that in any sea condition water will not penetrate into the vessel

Weld Metal Corrosion is a preferential corrosion of the weld deposit due to an electrolytic action between the weld metal and base metal.

Wind and Water Strakes are the strakes of a ship's side shell plating between the ballast and deepest load waterline.